

a c o u s t i c i n s u l a t i o n s y s t e m s
for new construction and refurbishing work

TECSOUND[®]
texsa



Second edition January 2004

© Copyright 2003 Texsa S.A. All rights reserved.

M 53670 - 2003

Total or partial reproduction of the text or the illustrations contained in this catalogue is absolutely prohibited, without the prior consent of Texsa S.A.

The information and data provided here have been prepared in good faith and considering them to be correct. We decline all liability for this information and data, and they do not represent any kind of guarantee.

Texsa S.A. reserves the right to amend the contents of this catalogue without prior notice, and declines any liability in the event of anomalies occasioned by misuse of the product.

Customer Service 901 11 66 12

Introduction:

Sound and its properties	Page 5
Absorption and acoustic insulation. General concepts	Page 9

Acoustic insulation systems

Index of Systems	Page 16
-------------------------	---------

Interior partitions

PI-1	Page 19
PI-2	Page 20
PI-3	Page 21
PI-4	Page 22

Partition walls

PM-1	Page 23
PM-2	Page 24
PM-3	Page 25
PM-4	Page 26
TR-1	Page 27
TR-2	Page 28

False ceilings

FT-1	Page 29
FT-2	Page 30

Floors

S-1	Page 31
S-2	Page 32
S-3	Page 33

Drainpipes

BJ-1	Page 34
------	---------

Metal roofs

CM-1	Page 35
CM-2	Page 36

Pitched timbered roofs

CI-1	Page 37
CI-2	Page 38

Technical Data Sheets

TECSOUND® 35, 70, 100	Page 40
TECSOUND® S 35, 70, 100	Page 41
TECSOUND® SY 50, 70	Page 42
TECSOUND® SY BANDA 50, 70	Page 43
TECSOUND® FT 40, 75	Page 44
TECSOUND® 2FT 45, 80	Page 45
TECSOUND® FT 55 AL	Page 46



Sound and its properties

Sound: physical description

Sound is a disturbance which is propagated (in the form of sound wave) through an elastic medium, producing variations in pressure or vibrations of particles which can be perceived by the human ear, or by instruments specifically for this purpose.

The movement of the particles is a simple harmonic movement, associated with a wave graph. When the air particles push against each other, they cause a compression of the fluid medium. When they go back to their position of equilibrium, a negative pressure or rarefaction takes place. The wave front is the spherical surface area enveloping the particles which have begun to vibrate at the same instant and are in the same phase or stage of vibration.

Characteristics of sound waves

The number of pressure variations per second is known as the **frequency (n)** of the sound, and is measured in Hertz (Hz) or in cycles per second (s^{-1}). The band of audible frequencies is broken down into three regions:

Low pitches:	From 125 Hz to 250 Hz.
Medium pitches:	From 500 Hz to 1000 Hz.
High pitches:	From 2000 Hz to 4000 Hz.

Each sound frequency produces a different pitch. A single-frequency sound is known as a pure tone but, in practice, pure tones are very rare and most sounds are made up of different frequencies.

The Period (T) is the time it takes to perform a complete cycle. It is measured in seconds. The wave amplitude tells us the dimension of the pressure variations. The larger the amplitude, the louder the sound will be. The wavelength (λ) is the distance travelled by a sound wave in one period of time. It is measured in metres. The propagation velocity (c) is the speed the sound waves are propagated at. There is a specific velocity for air (340 m/s), water (1,460 m/s), glass (5,000 to 6,000 m/s), etc. When we know the velocity (c) and frequency of a sound, we can calculate the wavelength, using the following ratio:

$$\lambda = \text{sound velocity} / \text{frequency} = c/n.$$

The commonest means for graphic representation of the sound or disturbance is the oscillogram, which indicates the evolution over time of the sound pressure, and tells us the frequency.

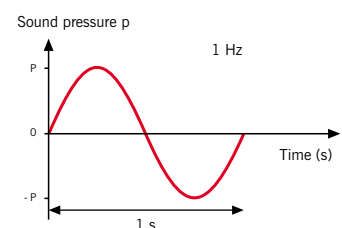
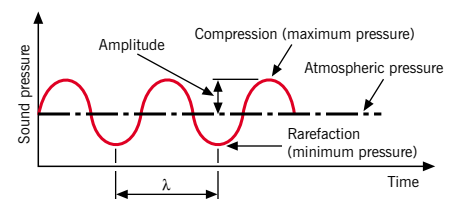

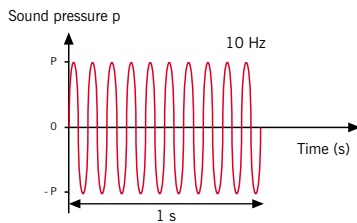

$$v_2 = 2v_1$$

$$v_2 = 2^{1/3} v_1$$

6

Spectral analysis and sound types

In the vast majority of cases, sounds are complex and they are generated by superposition of multiple frequencies. To represent a sound graphically, the frequency spectrum is used, including data on the frequencies it contains and their respective levels of sound pressure. The frequencies are usually grouped into what is known as **frequency bands**. Each band is made up of a certain number of frequencies: the ends and the middle frequency by which each band is designated are standardized. The frequency scale used is logarithmic, this being the one which best adjusts to the behaviour of the human ear. Bands can have a larger or smaller frequency content, which determines their **bandwidth**. Normally, bands are used with a width of **one octave**, which means that, in an interval of frequencies (n_1, n_2), the top frequency is twice the bottom one.

When greater resolution is required, a width of a **third of an octave** is used, obtained by dividing each octave band into three equal logarithmic intervals.

There are different types of sounds, defined as follows:

Pure sound: Sound made up of one single frequency.

Harmonic sound: sound made up of one fundamental frequency and a number of harmonics. Harmonics are multiple frequencies of the fundamental frequency.

Random sound: sound made up of several randomly related frequencies, not necessarily multiples of the fundamental frequency.

Noise

Noise or continuous spectrum is a set of random sounds in which there is a large number of frequencies very close to each other.

The definition of **white noise** is given to a standard noise characterized by its having an increment of 3 dB of the sound pressure in each increase of one octave band. Similarly, **pink noise** is defined as a noise with bands of octaves which all have the same sound level.

Traffic noise is also defined, and this places more importance on the low frequencies and reproduces the conditions of motorized vehicle traffic.

Properties of sound waves and propagation of sound.

During propagation of sound waves in a medium, a series of phenomena modifying their properties can occur.

When a wave meets an object in its path, its behaviour will depend on the frequency. If the wavelength \ll in respect of the size of the object, it will rebound off its surface, producing a **reflection** if it is smooth, or **diffusion** of the sound if it is uneven. If λ is similar to or smaller than the size of the object's surface, the wave will surround the obstacle. This behaviour is analogous to that of a wave which reaches a flat surface with a small hole. From the hole onwards, identical waves will be generated to the incident wave in all directions. This phenomenon is known as **diffraction**.

Each system has its own oscillation frequency; i.e. it always vibrates naturally at this frequency. If a disturbance forces this system with a frequency equal to the natural frequency, the body will vibrate with an amplitude which will gradually increase until the disturbance is eliminated. This phenomenon is defined as **resonance**.

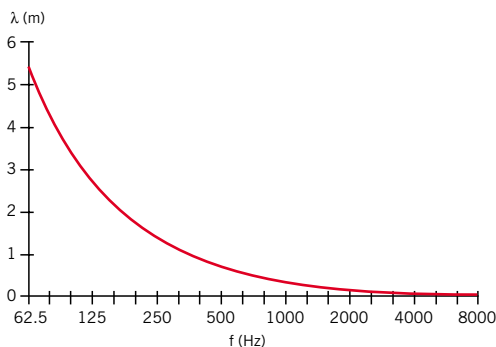

Units of measurement. The decibel scale

Sound pressure p is a variable increment of the atmospheric pressure, resulting from the presence or absence of sound. It is measured in **Pascals** (Pa). Due to these characteristics, it is sometimes more convenient to refer to other dimensions as a measure of the amplitude of sound. **Sound power** W is the amount of sound energy emitted by unit of time. Its value depends on the source of sound only, and not on its position in space. It is measured in Watts W .

Sound intensity I expressed in Watts/m² W/m^2 is the amount of sound energy crossing a unit of area perpendicular to the sound's propagation direction in the unit of time.

As can be observed, the three dimensions (pressure, power and intensity) are expressed in different units. However, it is possible to use an adimensional unit, assuming the logarithm of the quotient between a data value and a specific reference value as a reference. The most commonly used unit is the **decibel** dB, which enables easy handling of quantities which would otherwise be very cumbersome for making calculations.

The reference sound pressure level p_0 corresponds to 20 Pa, this being the minimum pressure variation detectable by the human ear (**hearing threshold**). An important aspect of the decibel scale is that it provides a more real approximation of the human perception of relative loudness than the linear scale in Pa. Moreover, using a logarithm scale, the dimensions cannot be directly added (for example: two machines with a sound power of 80 dB each will produce a total power of 83 dB, not 160 dB).

Using the above definitions, we can express in decibels the ratio between the sound power level of the source and the sound pressure originating in a point at distance r away.

In the case of spherical waves coming from a spot source being propagated in the air, we will get:

From this ratio, it can be deduced that, every time we double the distance, the sound pressure is diminished by 6 dB.

In the case of linear sources such as roads or railways, the sound is propagated in the form of cylindrical waves and the sound pressure originating in a point distance r away will be:

The reduction in this case will be 3 dB, doubling the distance.

Perception of sound and weighted scales. Decibels A

As we have already mentioned, the minimum sound pressure level detectable by the human ear is 20 Pa, corresponding to 0 dB, and known as the hearing threshold. Similarly, the **pain threshold** is defined as the maximum sound pressure bearable to the human ear. This value is around 140 dB (fig).

In the characterization and evaluation of the impact of sound sources on humans, it is important to consider that hearing sensitivity is not the same to all sounds and that the

The three dimensions are inter-related:

$$I = \frac{p^2}{\rho c} = \frac{W}{4\pi r^2}$$

Equation valid for a flat wave propagated in a free field.

Where

ρ = density of the medium

c = propagation speed of the sound wave.

r = distance between the source of sound and a specific point.

In general a level in dB is defined as:

$$\text{Level in dB} = 10 \log \frac{\text{Quantity}}{\text{Reference quantity}}$$

The levels of pressure, power and intensity expressed in dB will be:

Sound intensity level:

$$L_i = 10 \log \left[\frac{I}{I_0} \right]; I_0 = 10^{-12} W / m^2$$

Sound power level:

$$L_w = 10 \log \left[\frac{W}{W_0} \right]; W_0 = 10^{-12} W$$

Sound pressure level:

$$\text{SPL} = 10 \log \left[\frac{p^2}{p_0^2} \right] = 20 \log \left[\frac{p}{p_0} \right]; p_0 = 20 \mu\text{Pa}$$

$$L_p = L_w - 20 \log r - 11 \text{ (dB)}$$

$$L_p = L_w - 10 \log r - 8 \text{ (dB)}$$

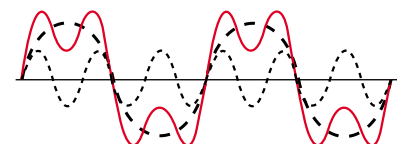

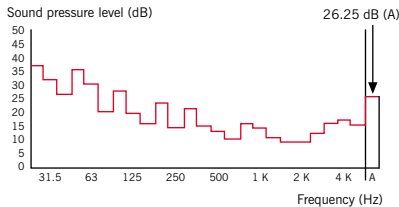

sensation is not linear in respect of the sound levels expressed in dB. Specifically, hearing sensitivity is higher for medium and high frequencies and much lower for low frequencies. It is also important to bear the following characteristics of sound in mind.

- a) The sum of two equal sources of sound produces an increment of 3 dB. (e.g.: 40 dB + 40 dB = 43 dB).
- b) An increment of 10 dB (10 times the sound) is needed for the ear to perceive twice the intensity (e.g.: 50 dB x 10 = 60 dB).
- c) If two sound levels are simultaneously emitted by two different sources and one of them is louder than the other by at least 10 dB, the resulting sound level will equal that originated by the louder (e.g.: 50 dB + 60 dB = 60 dB).

To express these concepts in graph form, **isophonic or equal-loudness curves** (fig) are used, representing the levels at each frequency for which the perception of sound is the same. Loudness is expressed in **phons**.

Based on the isophonic curves, **weighted scales or filters** are defined. Via these, the aim is to convert the spectrum of the exterior sound into one adjusted to the perception of the human ear, i.e. attenuating the low frequencies. The best known weighted scales are called A, B, C and D (fig). Filters A, B and C reproduce the isophonic curves at different levels, while filter D acts to characterize the discomfort caused by aircraft noise. The filter habitually used is A, as it satisfactorily describes all the levels of sound and generalizes the characterization of sound sources. Sound levels treated with filter A are measured in **decibels A (dBA)**.

It is important to stress that this scale, by discriminating low frequencies (which are the hardest to deal with and those most easily transmitted) can make a correct assessment of the noise in the domain of building difficult.

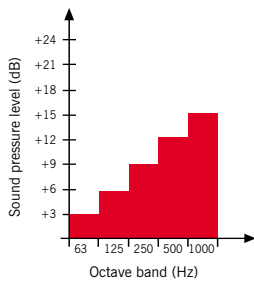

Combinations of sound levels and measuring sound

It is often necessary to calculate the effect resulting from several sources of sound. As the sound levels are expressed in logarithmic quantities, they cannot be added or subtracted arithmetically. The general formula for addition of units in decibels is as follows:

$$SPL_{total} = 10 \log \left[\sum_{i=1}^N 10^{L_i/10} \right] \text{ dB}$$

where L_i is each of the N sound levels to be added. To subtract levels, procedure is the same. To make these calculations easier, two graphs are used: one for addition and the other for subtraction of levels. Both are used by entering the difference between the higher level and the lower level ΔL on the X axis and adding or subtracting from the higher level the level corresponding to the Y axis (fig).

A highly practical system for measuring and evaluating noise problems is to use a **sound meter**. There are different types of sound meters, classified as "type 3" (inspection sound meter), "type 2" (general use sound meter) and "type 1" (precision sound meter), according to an increasing degree of precision. There are also "type 0" sound meters (standard sound meters). These instruments can give an instant result, or one integrated over a period of time (in dB). It is usually possible to convert the result into dBA by selecting filter A in the instrument.

"Type 3" is the most economical, and gives an approximate indication with wide tolerance. When the problem is more complex, a laboratory analysis using spectral analyzers will be needed.

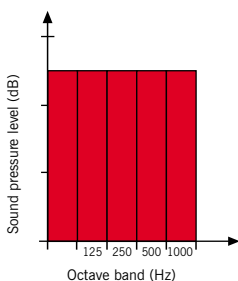

Absorption and acoustic insulation.

General concepts

Energy balance of sound

Sound waves incident on a surface produce a distribution of the energy they carry. Part of the incident energy will be reflected, part absorbed in the surface, part dissipated inside and another part transmitted.

Energy absorbed in the surface, E_{AS} is dissipated in the process of acoustic absorption which involves friction and transformation into heat energy. The energy E_{DI} is transformed into kinetic or potential energy inside the medium. In sum, the first addend represents the quantity of energy returning to the first medium and the second addend that crossing to the second medium. It is important to note that this expression indicates that, the more reflective the surface is, the less energy will cross to the second medium. On the other hand, if the absorption is increased, the reflected energy will diminish, but not the transmitted energy. For this to be reduced, we must dissipate more energy inside the second medium.

Absorption and absorption coefficient

Absorption is increased by using absorbent materials; i.e. materials characterized by their porous structure which dissipate the sound energy in heat. Energy loss also takes place through the vibrations caused when sound waves are incident on lightweight panels known as membrane echo boxes, or by phase opposition by the wave penetrating into cavities such as Helmholtz echo boxes. A material's absorption capacity depends on the frequency and is expressed by a laboratory-measured coefficient known as Sabine, as the formula used is W. Sabine's.

The lower α is, the lower the absorption per surface unit. The value of α increases with density and thickness.

The total amount of absorption in an enclosed area corresponds to the sum of all the partial absorptions of the different surfaces:

Absorption by people, furnishings and the air in the room, when it is very large, need to be added to this result.

The energy balance can be written as:

$$E_I = [E_R + E_{AS}] + [E_{DI} + E_T]$$

where

E_I = incident energy
 E_R = reflected energy
 E_{AS} = energy absorbed in the surface
 E_{DI} = energy dissipated inside
 E_T = energy transmitted

Coefficient α is defined as:

$$\alpha = \frac{E_{AS}}{E_I} = \frac{\text{Absorbed energy}}{\text{Incident energy}}; 0 \leq \alpha \leq 1$$

The amount of acoustic absorption A of a surface S is defined as:

$$A = S \cdot \alpha$$

and α being adimensional, it is expressed in m^2

$$A = \sum (S \cdot \alpha)$$

T_r is calculated using the general Sabine expression:

$$T_r = 0,161 \frac{V}{A + 4mV}$$

where

T_r = reverberation time (s)

V = volume of venue (m^3)

A = acoustic absorption of venue (m^2)

$4mV$ = Acoustic absorption of the air in the venue (for large premises only)

The $4m$ coefficients depend on the temperature and relative humidity of the venue.

$$T_r = 0,161 \frac{V}{A} ; V < 1.000 m^3$$

10

Reverberation time

The sound produced by a spot source of sound emitted into the open air is attenuated when propagated 6 dB every time the distance is doubled. For example, two people talking in an open space can hear their conversation only for the few moments the emission of each word lasts. This is not the case in an enclosed area, where sound can take much longer to become extinguished, due to the reflections off the walls, particularly if the enclosure has little acoustic absorption. This can cause loss of clarity of the conversation or generally of the sound emitted.

The parameter used to predict and characterize the responses of different premises to this phenomenon is reverberation time T_r , defined as the time needed for a sound pulse or a brusquely interrupted continuous sound to be attenuated 60 dB.

Reverberation time varies with frequency, and is longer at low than at medium and high frequencies.

For small premises, the above formula can be approximated with:

Acoustic conditioning and absorbent materials

Combined use of the parameters defined in the preceding sections has the purpose of identifying the best conditions for a venue to be acoustically well conditioned. Acoustic conditioning, often confused with acoustic insulation, by treating the surfaces with suitable materials, achieves the following:

- a) increasing internal acoustic comfort, reducing background noise.
- b) appointing a venue for it to meet specific requirements.
- c) ensuring that, from the project stage, a building meets the fundamental acoustic conditions for its purpose, such as a theatre, cinema or auditorium.

The materials used are characterized by having a structure comprised of pores connected to each other and to the outside. Closed-cell structure materials are not admissible as sound-absorbents. The most widely used products on the market can be split into two categories: fibrous materials and materials with open-cell structure.

a) Fibrous materials.

Rock wool and fibreglass are the materials most commonly used as sound-absorbents in false ceilings and double walls. They offer high resistance to high temperatures, as the raw material they are made of are siliceous minerals and volcanic rock. The recommended densities are from 40 to 70 kg/m^3 , as higher values would involve increased reflection. The thickness is variable, depending on the frequencies to be corrected, taking into consideration that absorption generally increases with thickness. There are also wall panels made of wood-chip agglomerate with magnesite which, being porous, find similar applications.

b) Open-cell structure materials.

The commonest are polyurethane foams. They are available in various thicknesses and are presented with pyramidal or honeycomb finishes. They are normally used as absorbent elements in walls and ceilings in recording studios and for machinery.

Other materials of this kind are melamine foams.

There are also closed-cell structure materials, such as cork or polystyrene. Despite their good behaviour as thermal insulators, these materials are lacking in sound-absorbent characteristics and should not be used as such, particularly in cavities between double walls, as they would reduce the insulation of the system.

Acoustic insulation: definition

Acoustic insulation is the chief method for controlling sound propagation in buildings. In particular, acoustic insulation has the job of reducing noise transmission between two premises or, in general, between one enclosed area and another. Insulation modifies the difference between acoustic intensity level L_1 in the emitting area and acoustic intensity level L_2 in the receptor area.

It is important to note that, when a venue is acoustically conditioned by fitting absorbent materials, what is achieved is to lower noise level L_1 , but the difference $L_2 - L_1$ remains unaltered.

Forms of noise transmission in structures

The noise between two enclosed areas in a building is transmitted by three different routes (fig):

- Directly through the surface.

In this case, the incident waves make the construction element vibrate, transmitting their deformation to the air in the adjacent area, causing the so-called “drum effect” or “diaphragm effect”. Noise transmitted by this mechanism is known as airborne noise.

- Flanking.

This is due to the fact that the sound pressure not only causes the dividing wall to vibrate, but also all the adjacent surfaces become noise-producing sources in the next-door area. A direct consequence of this phenomenon is that acoustic insulation calculated by taking only the dividing element into account will always be less than the actual.

- By direct impact on the structure.

Footsteps, vibrations caused by starting up machinery (lifts, washing machines, etc.) and in general any noise caused by direct impact with a construction element generates a series of vibrations which spread fast throughout the entire structure, with little energy loss. These noises are known as impact noise.

Transmission of airborne noise through the structure

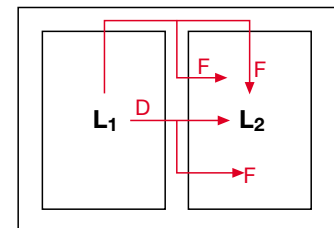

L1: emitting area D: direct transmission
L2: receptor area F: flanking

Airborne noise: measurement and related dimensions. Insulation indices

The commonest way to obtain acoustic insulation data for a construction element is to conduct laboratory tests. The standards establishing the measuring criteria for acoustic insulation and the way the results are expressed are as follows:

- UNE-EN ISO 140. Measurement of acoustic insulation in building and construction elements.

This standard describes the measuring methods and how the results are expressed.

- UNE-EN ISO 717 Evaluation of acoustic insulation in building and construction elements.

This describes the calculation methods enabling the data resulting from the measurements to be expressed in one single result.

It is important to bear in mind that the values obtained only take direct transmission into account, and not other parameters, such as the presence of installations or flanking, which weaken the hermetism of the premises. So, laboratory measurements represent an ideal result and the acoustic insulation figure will always be higher than that measured in situ.

Laboratory measurements are made by 1/3 of octave bands, whilst in situ, octave bands are generally used. The result is a curve which associates a value R to each frequency, known as **acoustic insulation index**. In both cases, it is possible to express the result with one single value which is known as the **weighted acoustic insulation index**. This index corresponds to the value of 500 Hz of an adjusted reference curve, and is calculated as indicated in ISO 717 standard. The symbol identifying it is R_w and it is measured in dB. The subscript w indicates that this value is weighted. Index R_w is normally accompanied by two correction factors, C and C_{tr} , **known as spectral adaptation terms**. The first term applies when there is a prevalence of pink noise, while the second applies when low frequencies are prevalent. So, the full expression of the R_w index is $R_w (C; C_{tr})$. It is important to note how the term C is applicable in calculating insulation between homes, while C_{tr} , representing city traffic noise, is used to calculate insulation in façades or fronts.

However, the Spanish standard **NBE CA-88** refers to R_A as the insulation index representing the **overall insulation value to pink noise**. R_A can be determined in the laboratory, by generating pink noise in the emitting room and measuring its level in dBA in the receptor room, by applying a correction taking account of the characteristics of the room. For in situ measurements, reference is made to gross acoustic insulation D , which is the difference in sound pressure levels between enclosed areas, and to $D_{nT,w}$ the **standardized weighted difference in levels**, which takes account of the reverberation time.

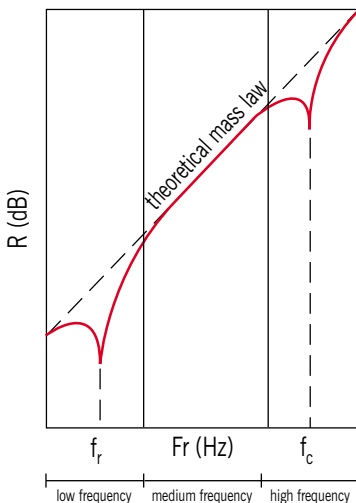

Theoretical mass law

$$R = 20 \lg (fm) - 42 \text{ dB}$$

f_r = resonance frequency (Hz)

f_c = coincidence frequency (Hz)

m = mass of the wall (Kg/m^2)

Construction systems and airborne noise insulation.

Airborne noise insulation can be achieved in different ways, depending on the mechanism operating and the type of construction element.

a) Single walls.

In a single wall, the acoustic insulation depends primarily on its surface mass (kg/m^2). Because of this, the general theoretical law enabling calculation of the insulation index R is known as the **mass law**.

In this case, the wall, under the impact of the sound wave, vibrates and transmits the noise to the next-door premises. The mass law provides that, the lighter and more rigid the wall is, the less insulation it will have. It also establishes that the insulation increases by 6 dB when the mass is doubled for a fixed frequency. In actual fact, this is only the case in the interval between 500 and 1000 Hz and up to 45 dB. The mass law is merely theoretical, and does not take into consideration other parameters affecting the insulation, such as the **resonance frequency f_0 and the critical frequency f_c** .

Resonance frequency is the frequency a wall naturally vibrates at when it receives the impact of a sound wave. The direction of the displacement is perpendicular to the surface and causes what is known as the "drum effect". It depends on the mass and the environmental conditions; i.e. how the wall is attached to the rest of the structure. Normally, f_0 falls into the zone of very low frequencies.

When a wall vibrates, deflection waves are produced on its surface. If the incident waves are at the same frequency as the deflection waves, then the transmission of energy is maximum and the insulation minimal. This frequency is known as **critical or coincidence frequency**, and depends on the material and thickness. Thin walls have a high f_0 and thick walls, a low f_0 .

b) Double walls.

Acoustic insulation can be increased by using double walls. However, this can be done in the case of lightweight walls, as the heavier (and more insulating) the wall, is, the more difficult it will be to increase the insulation. The solution is to build two single walls and space them a certain distance apart. This assembly will provide greater insulation than a single wall of equivalent mass, and represents a **mass-spring-mass** system. The factors reducing the insulation in this system are:

- Resonance frequency of the double wall f_0 as of the assembly. This depends on the masses and the spacing distance, and is lower at higher masses and/or distances.
- Critical frequencies of the two walls.
- Stationary waves in the air chamber, causing the “sounding box” effect.

The insulation can be increased by fitting a flexible, absorbent material, such as rock wool, in the chamber, so that the spring effect is increased and the stationary waves are eliminated. Another effective method, particularly for very rigid walls, is to use the *diaphragm effect*. This consists of filling the cavity with a material comprising a thin membrane with very low f_0 , positioned between two spring elements, such as felt or mineral wool. The spring elements prevent movement of the membrane when it is hit by the sound waves, and this causes greater dissipation of mechanical sound energy with the consequent increased insulation. It is important not to use sheets of polystyrene or other rigid foams which worsen the result from the acoustic viewpoint for the air chamber filling.

c) Plasterboard walls.

Plasterboard walls are widely used in hotels, offices, hospitals, etc. The advantage of this system is the possibility of achieving high insulation values with relatively little mass compared with traditional masonry walls. As they are lightweight systems, they have low insulation to low frequencies. To build them, self-supporting steel structures are used, comprising horizontal U-channels and vertical C-profiles of variable width.

Depending on the insulation level required, it is possible to use one or two independent structures. The channel width determines the air chamber between the plates, which are screwed down onto both sides of the structure. The critical frequency f_c is very high (2700–3000 Hz), and does not depend on the number of plates fitted. It is important to install materials such as polyester fibre or mineral wools inside the cavity, to increase the insulation.

Use of a visco-elastic membrane with a high surface mass, attached with plasterboards, will cause it to deform upon receiving the impact of the sound wave, reducing the transmission of vibrations and sound. In particular, this system enables the response to low and medium frequencies to be increased, and the system's resonance frequency to be reduced.

Impact noise. Related dimensions: $L_{n,w}$ and ΔL_w indices.

Transmission of impact noise and vibrations is reduced by reducing the amount of energy transmitted. As for airborne noise, laboratory tests are also conducted for impact noise, according to EN-ISO 140-6/7, using a standardized impact machine. The result will be a curve which associates a value L_n , **the standardized impact sound pressure level**, with each frequency. Using the EN ISO 717-2 standard, the curve can be summarized in one single value $L_{n,w}$ **the overall weighted impact sound pressure index**. In order to be able to compare the results obtained in different laboratories, a reference framework is used, fitted with the coatings or floating floors to be tested. The parameter measured is then a difference indicated as L_w , and it represents the **weighted reduction of the impact sound pressure level**.

Impact noise insulation systems.

As a general rule, there are two methods for performing this operation: positioning a highly flexible, elastic material, thick enough for it to function and at the same time finished, on the surface to be insulated, or disconnecting the surface the impact is produced on from the rest of the structure (floating floors). Floor coatings used can be carpeting of varying thickness (L_w up to 30 dB), vinyl products in several layers, or floating parquets which can provide L_w up to 20 dB.

The materials used for producing floating floors are:

- expanded polyethylene 5 and 10 mm thick (L_w up to 20 dB).
- rock wool or fibreglass of the appropriate density and thickness (30 - 40 mm). These materials need to be protected against the humidity contained in the surfacing mortar.
- Elasticized expanded polystyrene.
- High density polyurethane foams of differing thicknesses.
- Rubber.
- Composition cork with rubber.

It is very important to avoid connection of the floating element at the sides with the walls around the perimeter. This is achieved by bringing the material to the walls above the level the finished flooring will have, and then trimming away the excess.

Transmission of impact noise in the structure

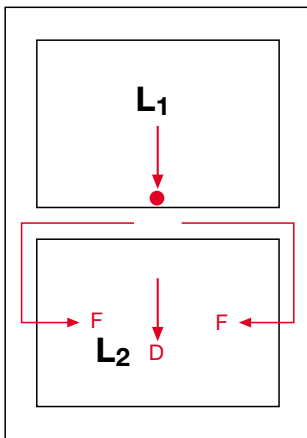

L1: emitting area D: direct transmission
L2: receptor area F: flanking

Acoustic insulation systems

The tests included in this catalogue were conducted in the following officially certified laboratories:

LGAI (Spain)
SRL Sound Reserch Laboratory (UK)
IEN - G Ferraris (Italy)

and with the collaboration of:

Sound Engineering Firm **ESTUDI ACÚSTIC FLAICAU**

in compliance with the following standards:

UNE - EN ISO 140-1
UNE - EN ISO 140-2
UNE - EN ISO 140-3
UNE - EN ISO 140-8
UNE - EN ISO 717-1 / 2

Index of Acoustic Insulation Systems

Constructions elements	Definition	TEXSA Product Name	Description of the system	Partition type	R _w (dB) or ΔL _w (dB)	Width rating (mm)	Page
Vertical elements Interior partitions	Dividing elements within same user's premises, in buildings for residential, public or healthcare use: -between areas for same use -between areas for different uses	PI-1	Interior partition, comprising a 46 mm central structure, fibreglass panel with a density of 15 kg/m ³ inside, TECSOUND® SY 70 on one face and two layers of sheet plaster, 13 mm thick per face.	T.S.	50	102	19
		PI-2	Interior partition, comprising a 46 mm central structure, fibreglass panel with a density of 15 kg/m ³ inside, TECSOUND® FT 40 on one face and two layers of sheet plaster, 13 mm thick per face.	T.S.	50,2	112	20
		PI-3	Interior partition, comprising a 70 mm central structure, rock wool panel with a density of 40 kg/m ³ inside, TECSOUND® SY 50 on both faces and two layers of sheet plaster, 13 mm thick per face.	T.S.	57,9	127	21
		PI-4	Interior partition, comprising a 46 mm central structure, rock wool panel with a density of 40 kg/m ³ inside, TECSOUND® SY 70 on one face and one layer of sheet plaster, 13 mm thick per face.	T.S.	46,4	84	22
Dividing walls between different users	Partition walls Walls between bedrooms Classroom divider walls (teaching use)	PM-1	Dividing partition, comprising 46 mm double structure, rock wool panel with d: 40 kg/m ³ inside each, TECSOUND® SY 70 adhered to the inner face of the double layer of sheet plaster 13 mm thick, all on both faces of the structural layer.	T.S.	54,5	144	23
		PM-2	Dividing partition, comprising double hollow-brick partition 70 mm thick, TECSOUND® 2FT 45 between the two, and plaster coat 15 mm thick on both outer faces.	T.H.	50	165	24
		PM-3	Dividing partition, comprising double perforated-brick partition 70 mm thick, TECSOUND® 2FT 80 between the two, and plaster coat 15 mm thick on both outer faces.	T.H.	56,6	167	25
		PM-4	Dividing partition, comprising 70 mm double structure, rock wool panel with d: 40 kg/m ³ inside each, TECSOUND® SY 70 adhered to the inner face of the double layer of sheet plaster 13 mm thick, all on both faces of the structural layer.	T.S.	57	200	26
Dividing walls for communal interior areas	Dividing walls for enclosed areas in homes or staircases, entry halls, corridors for access or service premises, in residential, healthcare and teaching use.	TR-1	Structural double hollow-brick wall rendered on the outside and inside, by application of TECSOUND® 2FT 45, 46 mm structure, fibreglass panel with d: 15 kg/m ³ inside and double layer of sheet plaster 13 mm thick.	T.S.	58,3	145	27
		TR-2	Structural double hollow-brick wall rendered on the outside and inside, by application of 46 mm structure, rock wool panel with d: 40 kg/m ³ inside, TECSOUND® SY 70 and double layer of sheet plaster 13 mm thick.	T.S.	53,7	230	28
Façades and fronts	Vertical construction elements or those with a gradient of over 60°, dividing the living space from the outside.	FT-1	Structural double hollow-brick wall rendered on the outside and inside, by application of 46 mm structure, rock wool panel with d: 40 kg/m ³ inside, TECSOUND® SY 70 and double layer of sheet plaster 13 mm thick.	T.S.	53,7	230	29
		FT-2					30

Constructions elements	Definition	TEXSA Product Name	Description of the system	Partition type	R _w (dB) or ΔL _w (dB)	Width rating (mm)	Page
Horizontal elements for division of properties	Ceiling, framework and overlap assembly. Airborne noise insulation R. Standardized impact noise level L _n in under space	FT-1	False ceiling comprising structure suspended from dampers, 50 mm air chamber, rock wool panel with d: 60 kg/m ³ , TECSOUND® SY 70 installed between the two layers of sheet plaster 13 mm thick.	T.S.	50	100	29
		FT-2	False ceiling comprising TECSOUND® FT 75, 20 cm air chamber, structure suspended from dampers, rock wool panel with d: 60 kg/m ³ , TECSOUND® SY 70 installed between the two layers of sheet plaster 13 mm thick.	T.S.	57,5	244	30
		S-1	Impact noise acoustic insulation system by installation of TEXSILEN 5 MM membrane over the framework, layer of mortar and flooring.		20		31
		S-2	Impact noise acoustic insulation system by installation of TEXSILEN 10 MM membrane over the framework, layer of mortar and flooring.		19		32
		S-3	Impact noise acoustic insulation system by installation over the framework of: TECSOUND® 70, TEXSILEN 5 MM membrane and floating parquet flooring.				33
Drainpipes		BJ-1	Drainpipe acoustic insulation comprising one or more layers of TECSOUND® FT 55 AL fitted around the drainpipe.		25		34
Roofs	Element comprising ceiling, framework and roof covering.	CM-1	Acoustic insulation system for metal roof, between the fretwork sheet and the insulating layer of AISLADECK BV installing the TECSOUND® 50 AL, which, in addition to reducing vibrations, provides the system with a vapour barrier and good fire reaction F1.		35	40	35
		CM-2	Metal roof system with built-in mineral wool panels for thermal insulation. Fitting TECSOUND® 50 AL gives the system mass and reduces the vibrations of the metal sheet.		38	90	36
		CI-1	Acoustic insulation system for pitched roofs with low thermal inertia, comprising inner timbered finish, TECSOUND® SY 70, WALLMATE CW thermal insulating layer, ventilation chamber, TECSOUND® FT 75, spruce board supporting Tegola Canadese shingles or the slate.		48	155	37
		CI-2	Acoustic insulation for pitched roofs with low thermal inertia, comprising inner finish of double-layer sheet plaster 13 mm thick, TECSOUND® SY 70, fibreglass thermal insulating layer, spruce board supporting attachment footing piece of the mixed roof.		50,2	180	38

Notes:

D.P. dry partition walls
W.P. wet partition walls

In all the systems, fitting TECSOUND® SY BANDA between the structure of the partition wall and its enclosures has been planned for. These systems are applicable in all new construction buildings, intended for any of the following uses:

- private residences
- public residences (hotels and residential homes)
- administrative and office space
- healthcare
- teaching use

Interior partition, comprising a 46 mm central structure, fibreglass panel with a density of 15 kg/m³ inside, TECSOUND® SY 70 on one face and two layers of sheet plaster, 13 mm thick on one face.

R_w 51 dB

Using TECSOUND® SY 70 with layers of sheet plaster considerably enhances their behaviour at low frequencies. Fitting the visco-elastic membrane between the sheet plaster and the metal structure eliminates the acoustic bridge between the two materials.

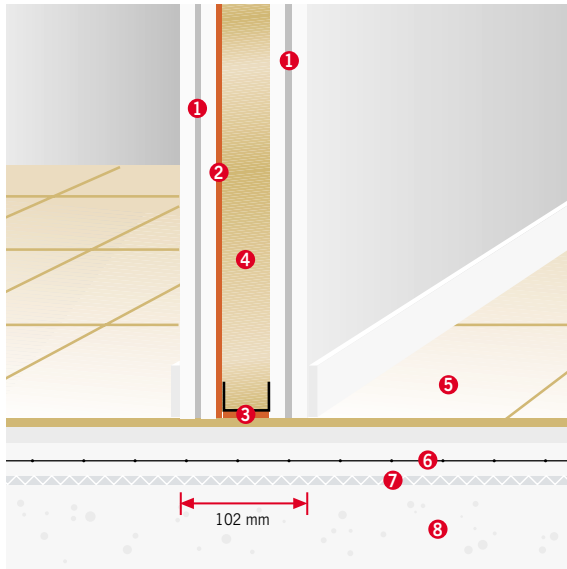

- | | |
|---|----------------------|
| 1. 2 layers of 13 mm gypsum plasterboard | 5. Flooring |
| 2. TECSOUND® SY 70. | 6. Reinforced mortar |
| 3. TECSOUND® SY BANDA 50 | 7. TEXSILEN 5 MM |
| 4. Fibreglass (th: 50 mm; d: 15 kg/m ³) | 8. Framework |

Fitting TECSOUND®

- TECSOUND® SY BANDA 50.
Before installing the metal structure, TECSOUND® SY BANDA 50 should be adhered to it and throughout the perimeter, in the area in contact with the support.
- TECSOUND® SY 70.
The TECSOUND® SY 70 should be fitted to the plaster sheet as follows:
 - Lay the plaster sheet horizontally over trestle tables.
 - Lay the roll of TECSOUND® SY 70 over the plaster sheet so that the width matches that of the roll, ensuring that 1 cm of membrane protrudes at each side.
 - Pull out the roll, gradually peeling away the protective silicon-coated paper. Check the membrane is parallel to the sheet at all times. Continue the operation until the entire surface of the sheet is covered.
 - Trim any excess material.
 - Fit the sheet with TECSOUND® SY 70 so that the membrane is installed between the structure work and the first sheet.

Join with ceiling

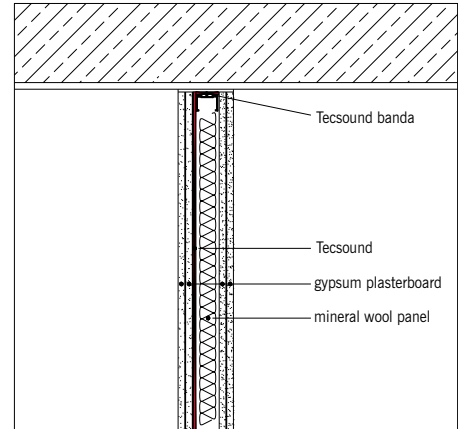

Join with floor

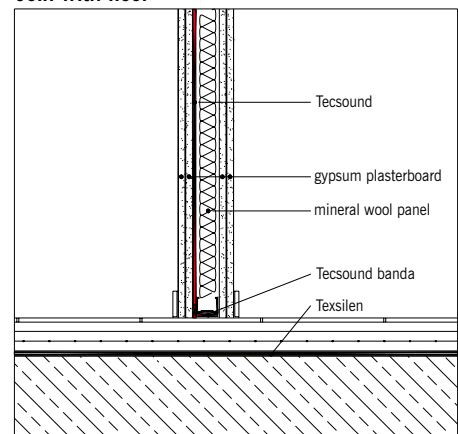

Comparative acoustic insulation graph

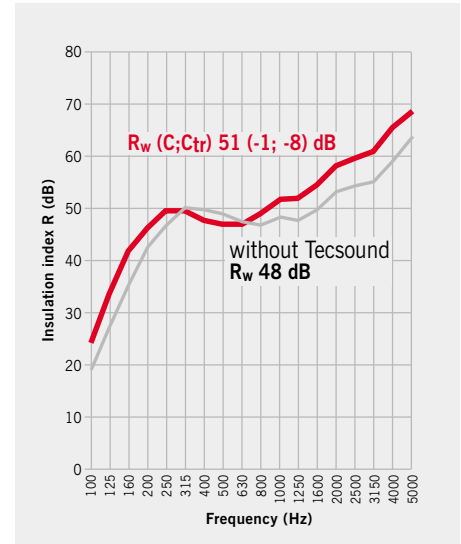

— LGAI (Spain) n° 20,012,331
— LGAI (Spain) n° 20,012,327

Freq.(Hz)	125	250	500	1000	2000	4000
— R (dB)	33.5	49.5	47.0	51.5	58.0	65.5
— R (dB)	27.0	47.0	48.5	48.0	53.0	59.0

Interior partition, comprising a 46 mm central structure, fibreglass panel with a density of 15 kg/m³ inside, TECSOUND® FT 40 on one face and two layers of sheet plaster, 13 mm thick per face.

R_w 53 dB

Using TECSOUND® FT 40 enhances the behaviour of the system at low and medium frequencies, thanks to its twin insulating/absorbent function supplied by the TECSOUND® membrane on one side and the textile felt on the other.

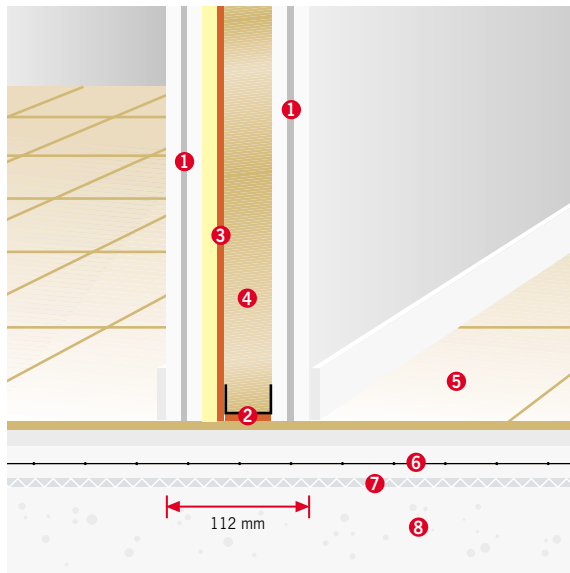

1. 2 layers of 13 mm gypsum plasterboard
2. TECSOUND® SY BANDA 50
3. TECSOUND® FT 40
4. Fibreglass (th: 50 mm; d: 15 kg/m³)
5. Flooring
6. Reinforced mortar
7. TEXSILEN 5 MM
8. Framework

Fitting TECSOUND®

1. TECSOUND® SY BANDA 50.
Before installing the metal structure, TECSOUND® SY BANDA 50 should be adhered to it and throughout the perimeter, in the area in contact with the support.
2. TECSOUND® FT 40.
The TECSOUND® FT 40 should be fitted to the plaster sheet as follows:
 - 1) Lay the plaster sheet horizontally over trestle tables.
 - 2) Cut the roll of TECSOUND® FT 40 into strips 1.20 m long.
 - 3) Adhere TECSOUND® FT 40 to the plaster sheet with LS Adhesive, starting at one end, and so that the felt is in contact with the sheet.
 - 4) Trim any excess material.
 - 5) Fit the sheet with TECSOUND® FT 40 so that it is in contact with the structure.

Join with ceiling

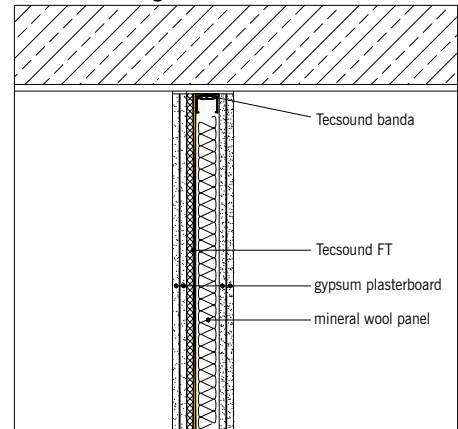

Join with floor

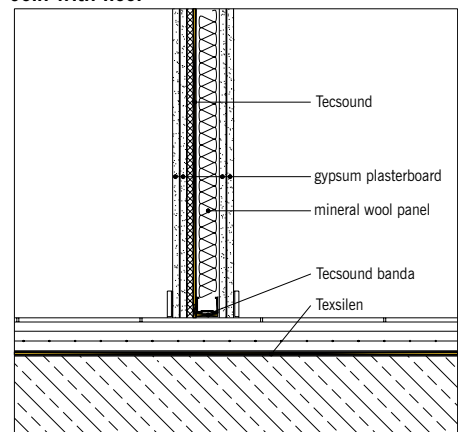

Comparative acoustic insulation graph

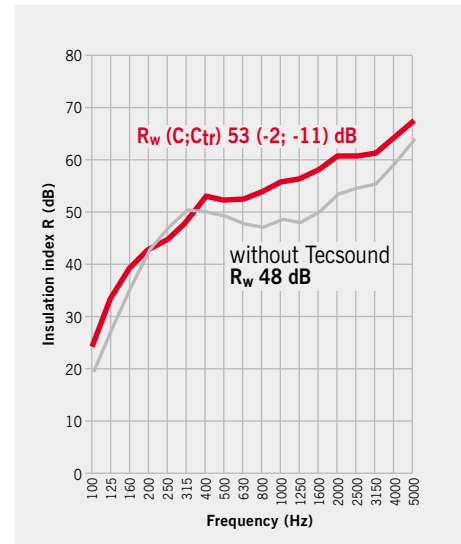

— LGAI (Spain) n° 20,012,332

— LGAI (Spain) n° 20,012,327

Freq. (Hz)	125	250	500	1000	2000	4000
— R (dB)	33.0	39.0	52.0	55.5	60.0	64.0
— R (dB)	27.0	47.0	48.5	48.0	53.0	59.0

Interior partition, comprising a 70 mm central structure, rock wool panel with a density of 40 kg/m³ inside, TECSOUND® SY 50 on both faces and two layers of sheet plaster, 13 mm thick per face.

R_w 59.9 dB

Using TECSOUND® SY 50 on both sides of the sheet plaster wall provides high acoustic insulation to airborne noise throughout the whole range of frequencies. This solution is particularly suitable for offices and interior divisions in homes.

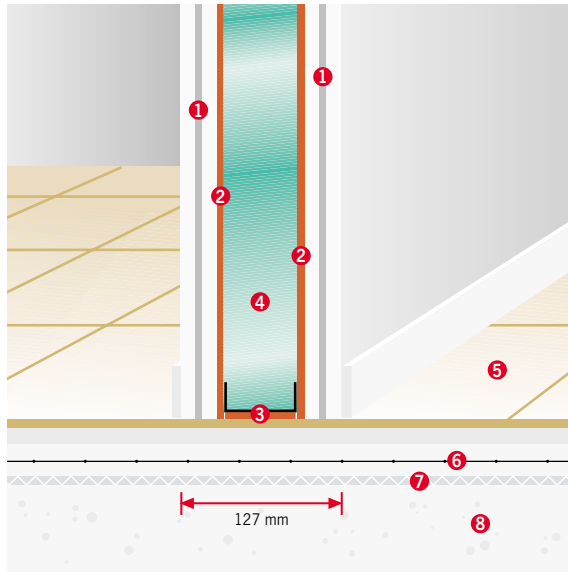

- | | |
|--|----------------------|
| 1. 2 layers of 13 mm gypsum plasterboard | 5. Flooring |
| 2. TECSOUND® SY 50 | 6. Reinforced mortar |
| 3. TECSOUND® SY BANDA 70 | 7. TEXSILEN 5 MM |
| 4. Rock wool (th: 70 mm; d: 40 kg/m ³) | 8. Framework |

Fitting TECSOUND®

- TECSOUND® SY BANDA 70.
Before installing the metal structure, TECSOUND® SY BANDA 70 should be adhered to it and throughout the perimeter, in the area in contact with the support.
- TECSOUND® SY 50.
The TECSOUND® SY 50 should be fitted to the plaster sheet as follows:
 - Lay the plaster sheet horizontally over trestle tables.
 - Lay the roll of TECSOUND® SY 50 over the plaster sheet so that the width matches that of the roll, ensuring that 1 cm of membrane protrudes at each side.
 - Pull out the roll, gradually peeling away the protective silicon-coated paper. Check the membrane is parallel to the sheet at all times. Continue the operation until the entire surface of the sheet is covered.
 - Trim any excess material.
 - Fit the sheet with TECSOUND® SY 50 so that the membranes are installed between the structure work and the first sheets.

Join with ceiling

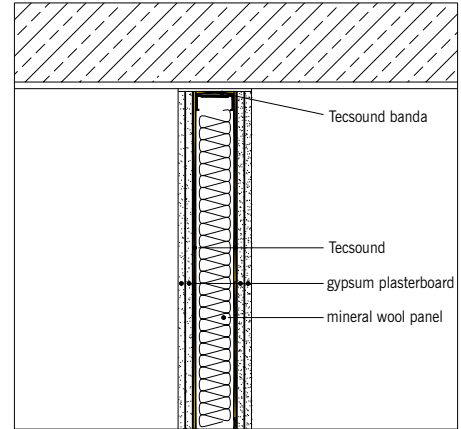

Join with floor

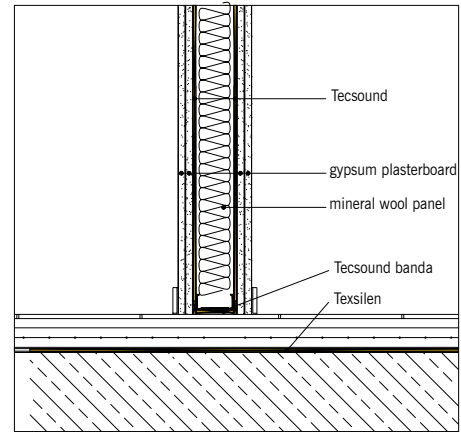

Comparative acoustic insulation graph

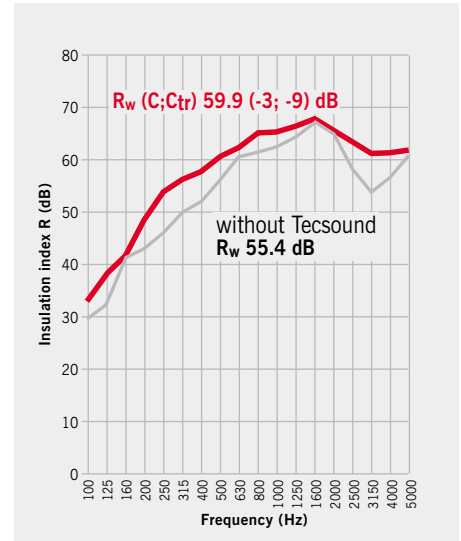

— IEN-G.Ferraris (Italy) n° 34478-01

— Inst. de acústica (Spain) AC3-D5-00-II

Freq.(Hz)	125	250	500	1000	2000	4000
— R (dB)	37.5	52.6	59.3	64.3	65.1	61.1
— R (dB)	34.7	46.5	56.2	62.3	64.2	57.0

Interior partition, comprising a 46 mm central structure, rock wool panel with a density of 40 kg/m³ inside, TECSOUND® SY 70 on both faces and one layer of sheet plaster, 15 mm thick per face.

R_w 48 dB

Alternative system to the PI-3 with reduced thickness. Using TECSOUND® SY 70 on both sides of the sheet plaster wall provides high acoustic insulation to airborne noise throughout the whole range of frequencies. This solution is particularly suitable for offices and interior divisions in homes.

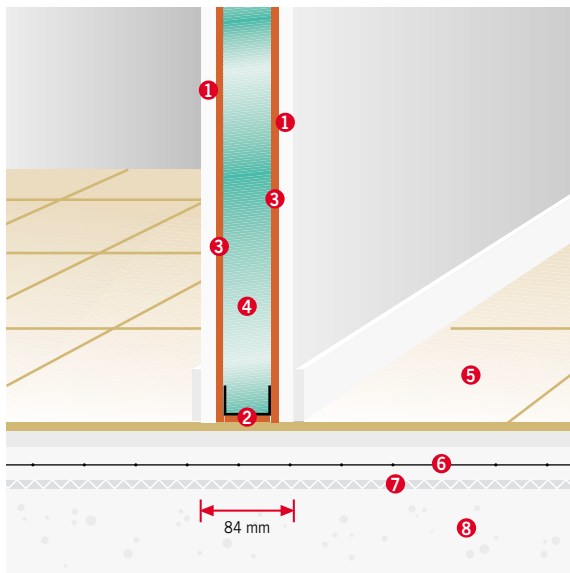

- | | |
|--|----------------------|
| 1. Layer of 15 mm gypsum plasterboard | 5. Flooring |
| 2. TECSOUND® SY BANDA 50 | 6. Reinforced mortar |
| 3. TECSOUND® SY 70 | 7. TEXSILEN 5 MM |
| 4. Rock wool (th: 50 mm; d: 40 kg/m ³) | 8. Framework |

Fitting TECSOUND®

- TECSOUND® SY BANDA 50.
Before installing the metal structure, TECSOUND® SY BANDA 50 should be adhered to it and throughout the perimeter, in the area in contact with the support.
- TECSOUND® SY 70.
The TECSOUND® SY 70 should be fitted to the plaster sheet as follows:
 - Lay the plaster sheet horizontally over trestle tables.
 - Lay the roll of TECSOUND® SY 70 over the plaster sheet so that the width matches that of the roll, ensuring that 1 cm of membrane protrudes at each side.
 - Pull out the roll, gradually peeling away the protective silicon-coated paper. Check the membrane is parallel to the sheet at all times. Continue the operation until the entire surface of the sheet is covered.
 - Trim any excess material.
 - Fit the sheet with TECSOUND® SY 70 so that the membranes are installed between the structure work and the first sheets.

Join with ceiling

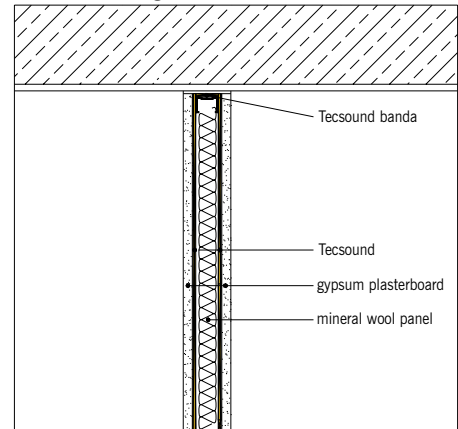

Join with floor

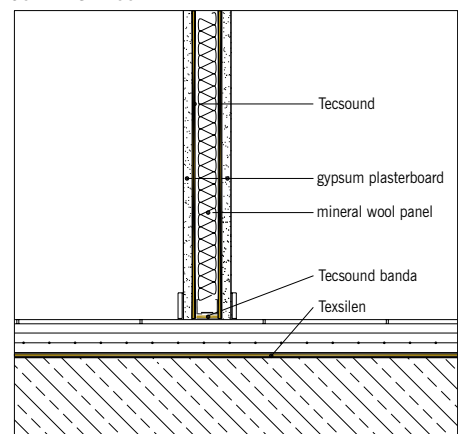

Comparative acoustic insulation graph

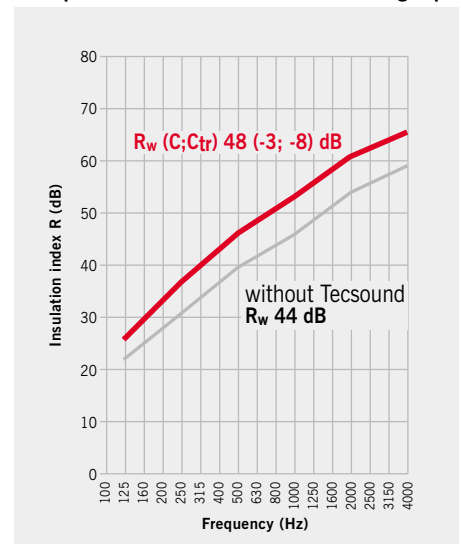

- Estudi Acústic H. Arau (Spain)
- Estudi Acústic H. Arau (Spain)

Freq.(Hz)	125	250	500	1000	2000	4000
R (dB)	26.9	37.2	46.0	52.7	60.4	65.7
R (dB)	21.8	30.8	39.2	45.7	53.3	58.8

This test was conducted with a numerical calculation value which gives a very close result to the actual insulation value.

Dividing partition, comprising a 46 mm double structure, rock wool panel with a density of 40 kg/m³ inside each, **TECSOUND® SY 70** adhered to the inside of the double layer of sheet plaster 13 mm thick, all the above on both faces of the structural layer.

R_w 56 dB

The double structure solution is highly indicated when specially high insulation levels are required between enclosed areas. A typical application of this system is to use it as a partition wall between conference rooms and bedrooms in hotels.

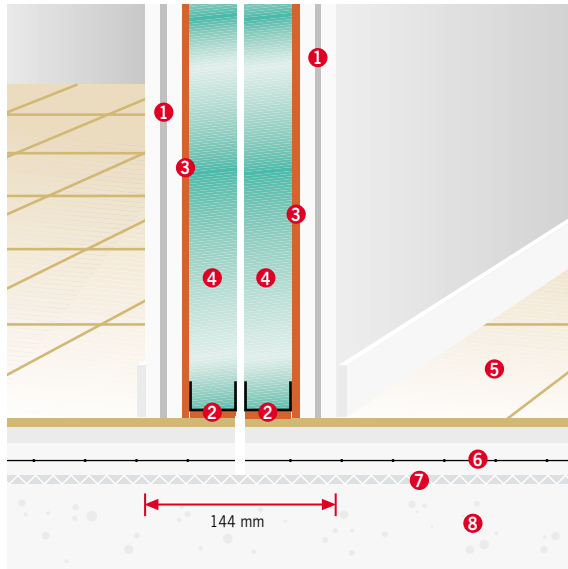

1. 2 layers of 13 mm gypsum plasterboard
2. TECSOUND® SY BANDA 50
3. TECSOUND® SY 70
4. Rock wool (th: 50 mm; d: 40 kg/m³)
5. Flooring
6. Reinforced mortar
7. TEXSILEN 5 MM
8. framework

Fitting TECSOUND®

1. TECSOUND® SY BANDA 50.
Before installing the metal structure, TECSOUND® SY BANDA 50 should be adhered to it and throughout the perimeter, in the area in contact with the support.
2. TECSOUND® SY 70.
The TECSOUND® SY 70 should be fitted to the plaster sheet as follows:
 - 1) Lay the plaster sheet horizontally over trestle tables.
 - 2) Lay the roll of TECSOUND® SY 70 over the plaster sheet so that the width matches that of the roll, ensuring that 1 cm of membrane protrudes at each side.
 - 3) Pull out the roll, gradually peeling away the protective silicon-coated paper. Check the membrane is parallel to the sheet at all times. Continue the operation until the entire surface of the sheet is covered.
 - 4) Trim any excess material.
 - 5) Fit the sheets with TECSOUND® SY 70 so that the membranes are incorporated between a sheet and the structure work.

Join with ceiling

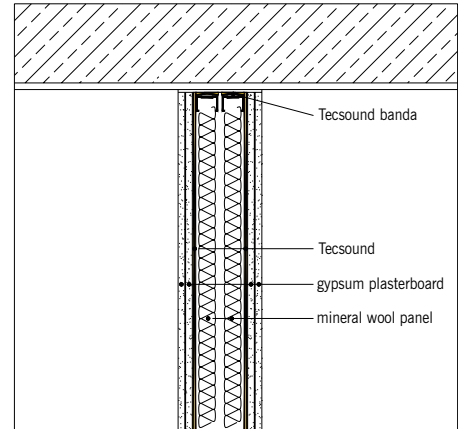

Join with floor

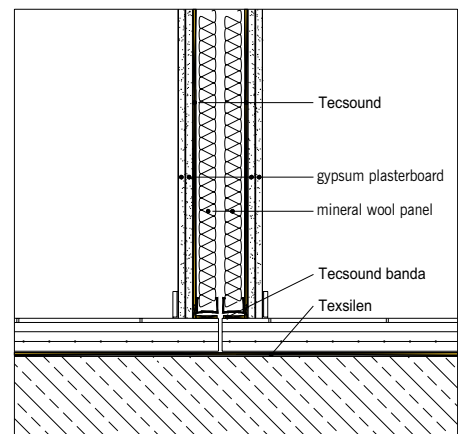

Comparative acoustic insulation graph

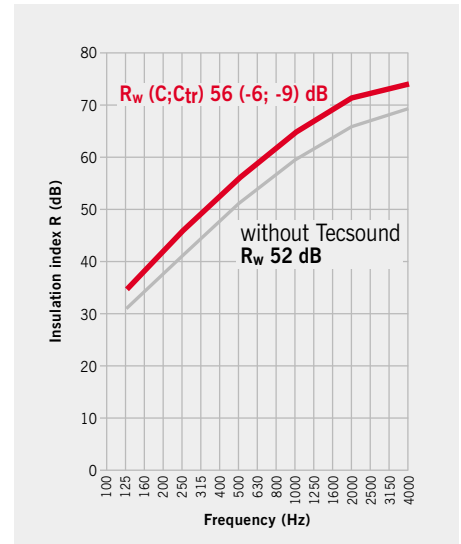

- Estudi Acústic H. Arau (Spain)
- Estudi Acústic H. Arau (Spain)

Freq.(Hz)	125	250	500	1000	2000	4000
— R (dB)	34.4	45.7	55.8	64.1	71.4	73.9
— R (dB)	30.6	41.3	51.2	59.4	66.6	69.2

This test was conducted with a numerical calculation value which gives a very close result to the actual insulation value.

Dividing partition, comprising double hollow-brick partition 70 mm thick, TECSOUND® 2FT 45 between the two, and plaster coat 15 mm thick on both outer faces.

R_w 50 dB

Installing the acoustic complex TECSOUND® 2FT 45 between two brick partitions provides a double absorbent / insulating function at the same time, thanks to the combination of porous materials and TECSOUND® membrane with high density and elasticity. The entire structure behaves like a mass-spring-mass system, much more efficient than a similar one with hollow air chamber.

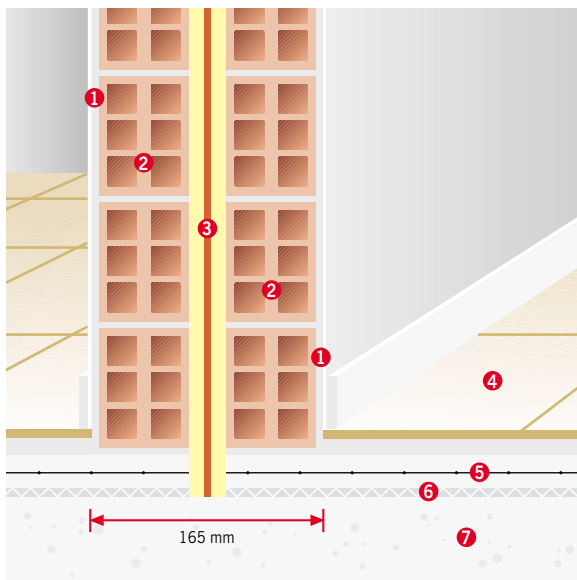

- 1. Plaster coat (th: 1.5 cm)
- 2. Double hollow brick (th: 7 cm)
- 3. TECSOUND® 2FT 45
- 4. Flooring
- 5. Reinforced mortar
- 6. TEXSILEN
- 7. Framework

Join with ceiling



Join with floor

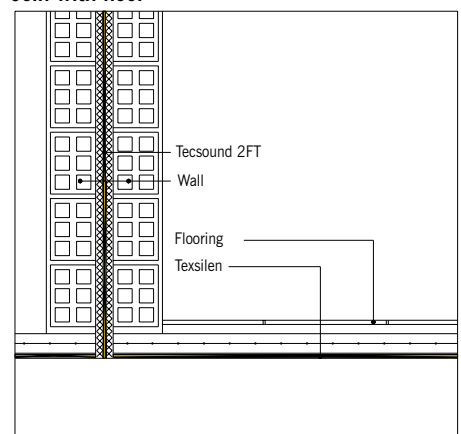

24

Fitting TECSOUND®

1. TECSOUND® 2FT 45.

Once the first partition has been set up, TECSOUND® 2FT 45 should be adhered to the surface with LS ADHESIVE, according to the following steps:

- 1) Make sure the support is clean, dry and preferably plastered. For restoration work, a check should be made that the plaster coat is in good condition and, in particular, that its surface is compact and even. Otherwise, the surface should be repaired before applying the LS ADHESIVE.
- 2) Apply LS ADHESIVE with a short-nap roller over the partition and to the TECSOUND® 2FT 45 felt. Wait for 15-20 minutes.
- 3) Line the TECSOUND® 2FT 45 up over the support and put in place. Make sure that the product is properly in contact with the top and bottom framework.
- 4) Repeat the same operation throughout the area of the partition, making careful overlaps between two consecutive sides. The overlap should be sealed using the same adhesive.
- 5) Next, set up the second partition, without leaving an air chamber.

Comparative acoustic insulation graph

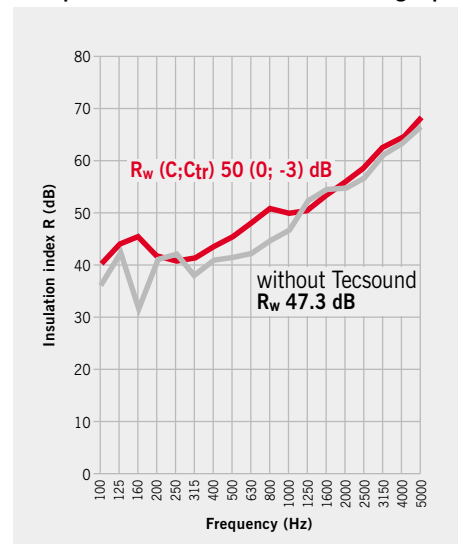

— LGAI (Spain) n° 20,009,299

— IEN-G.Ferraris (Italy) n° 34920-03

Freq.(Hz)	125	250	500	1000	2000	4000
— R (dB)	43.5	40.5	45.0	49.5	55.5	64.0
— R (dB)	42.4	42.1	41.7	47.9	54.4	63.7

Dividing partition, comprising double perforated-brick partition 70 mm thick, TECSOUND® 2FT 80 between the two, and plaster coat 15 mm thick on both outer faces.

R_w 57 dB

The new Technical Building Code CTE will increase the airborne noise insulation parameter in divisions between different users to 50 dBA. Combined use of perforated brick and TECSOUND® 2FT 80 enables this insulation level to be met. The entire structure behaves like a mass-spring-mass system, much more efficient than a similar one with hollow air chamber.

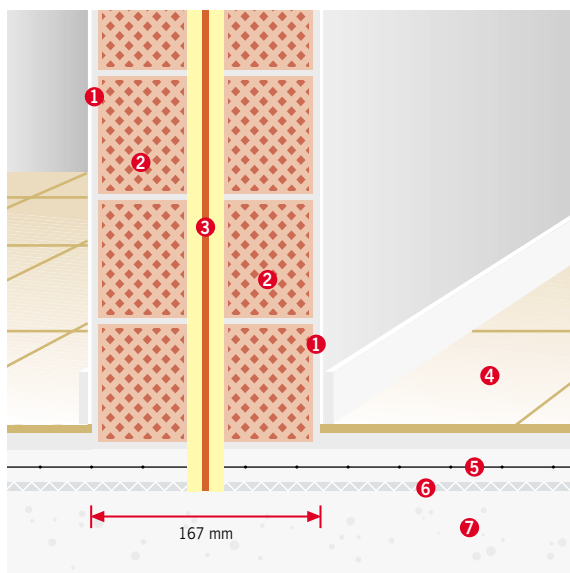

- | | |
|--------------------------------|----------------------|
| 1. Plaster coat (th: 1.5 cm) | 5. Reinforced mortar |
| 2. Perforated brick (th: 7 cm) | 6. TEXSILEN |
| 3. TECSOUND® 2FT 80 | 7. Framework |
| 4. Flooring | |

Fitting TECSOUND®

- TECSOUND® 2FT 80.
Once the first partition has been set up, TECSOUND® 2FT 80 should be adhered to the surface with LS ADHESIVE, according to the following steps:
 - Make sure the support is clean, dry and preferably plastered. For restoration work, a check should be made that the plaster coat is in good condition and, in particular, that its surface is compact and even. Otherwise, the surface should be repaired before applying the LS ADHESIVE.
 - Apply LS ADHESIVE with a short-nap roller over the partition and to the TECSOUND® 2FT 80 felt. Wait for 15-20 minutes.
 - Line the TECSOUND® 2FT 80 up over the support and put in place. Make sure that the product is properly in contact with the top and bottom framework.
 - Next, set up the second partition, without leaving an air chamber.

Join with ceiling

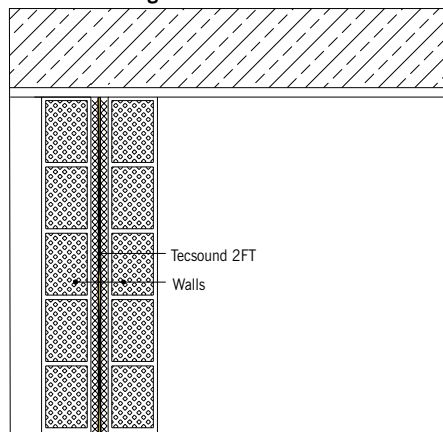

Join with floor

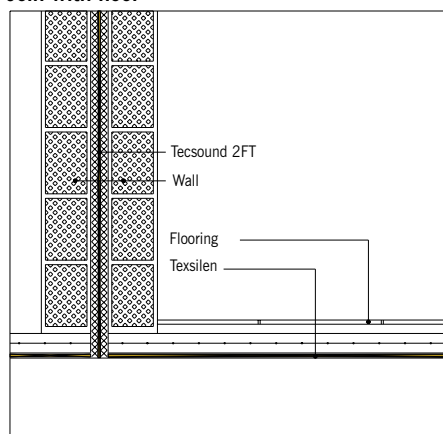

Comparative acoustic insulation graph

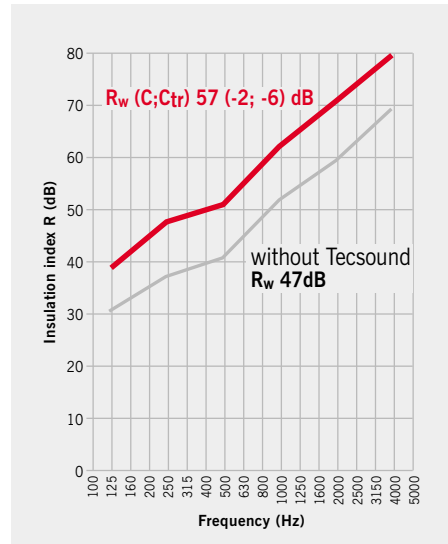

- Estudi Acústic H. Arau (Spain)
- Estudi Acústic H. Arau (Spain)

Freq.(Hz)	125	250	500	1000	2000	4000
— R (dB)	39.3	48.4	51.3	62.7	70.8	79.9
— R (dB)	30.3	37.7	41.0	52.4	59.9	69.0

This test was conducted with a numerical calculation value which gives a very close result to the actual insulation value.

Dividing partition, comprising 70 mm double structure, rock wool panel with $d: 40 \text{ kg/m}^3$ inside each, TECSOUND® SY 70 adhered to the inner face of the double layer of sheet plaster 13 mm thick, all on both faces of the structural layer.

R_w 58 dB

Double partition system for acoustic insulation and conditioning of cinemas when high performance characteristics are required in separating the different theatres. It comprises two independent structures 70 mm wide, filled with mineral wool and two layers of sheet plaster on each side. The TECSOUND® SY 70 used to double the sheets acts as a damper element, thanks to its high elasticity, and it contributes to increasing the surface mass of the structural wall, enhancing the performance at low frequencies. To enhance the reverberation time of the theatre, different finishes can be used once installation of the wall is complete.

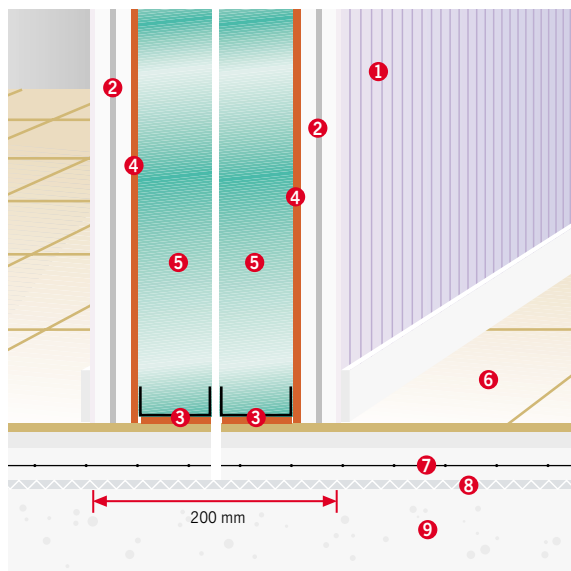

- | | |
|---|----------------------|
| 1. Sound-absorbent finish | 6. Flooring |
| 2. 2 layers of 13 mm gypsum plasterboard | 7. Reinforced mortar |
| 3. TECSOUND® SY BANDA 70 | 8. TEXSILEN 5 MM |
| 4. TECSOUND® SY 70 | 9. Framework |
| 5. Rock wool (th: 70 mm; d: 40 kg/m^3) | |

Fitting TECSOUND®

- TECSOUND® SY BANDA 70.
Before installing the metal structure, TECSOUND® SY BANDA 50 should be adhered to it and throughout the perimeter, in the area in contact with the support.
- TECSOUND® SY 70.
The TECSOUND® SY 70 should be fitted to the plaster sheet as follows:
 - Lay the plaster sheet horizontally over trestle tables.
 - Lay the roll of TECSOUND® SY 70 over the plaster sheet so that the width matches that of the roll, ensuring that approx. 1 cm of membrane protrudes at each side.
 - Pull out the roll, gradually peeling away the protective silicon-coated paper. Check the membrane is parallel to the sheet at all times. Continue the operation until the entire surface of the sheet is covered.
 - Trim any excess material.
 - Fit the sheets with TECSOUND® SY 70 so that the membranes are installed between one sheet and the structure work. The appropriate finish is applied once the partition is complete.

Join with ceiling

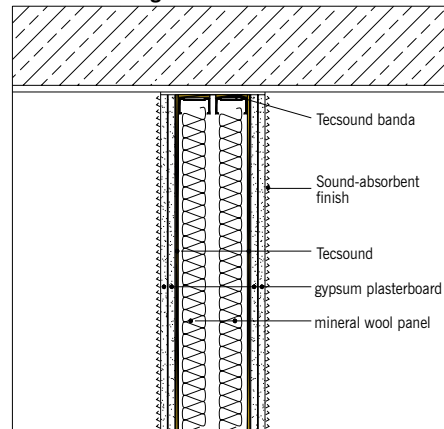

Join with floor

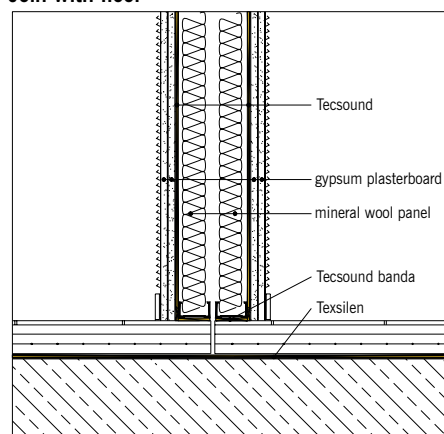

Comparative acoustic insulation graph

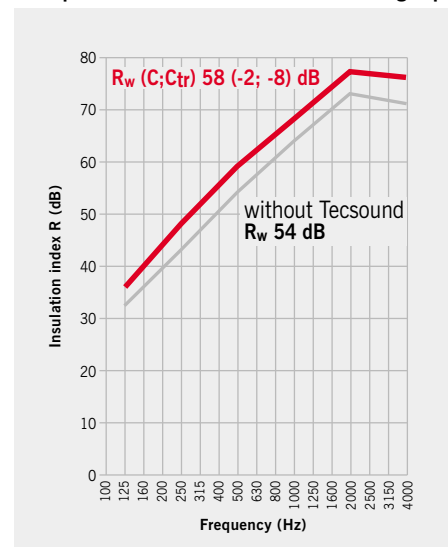

- Estudi Acústic H. Arau (Spain)
- Estudi Acústic H. Arau (Spain)

Freq.(Hz)	125	250	500	1000	2000	4000
R (dB)	36.5	48.3	59.4	68.4	77.6	75.8
— R (dB)	32.7	43.9	54.8	63.7	72.8	71.0

This test was conducted with a numerical calculation value which gives a very close result to the actual insulation value.

Structural double hollow-brick wall rendered on the outside and inside, by application of TECSOUND® 2FT 45, 46 mm structure, fibreglass panel with $d: 15 \text{ kg/m}^3$ inside and double layer of sheet plaster 13 mm thick.

R_w 59 dB

A system designed for restoration of residential spaces. Incorporation of the TECSOUND® 2FT 45 between the wall to be restored and the dry partition structure increase the sound-insulating power of the system in a reduced thickness.

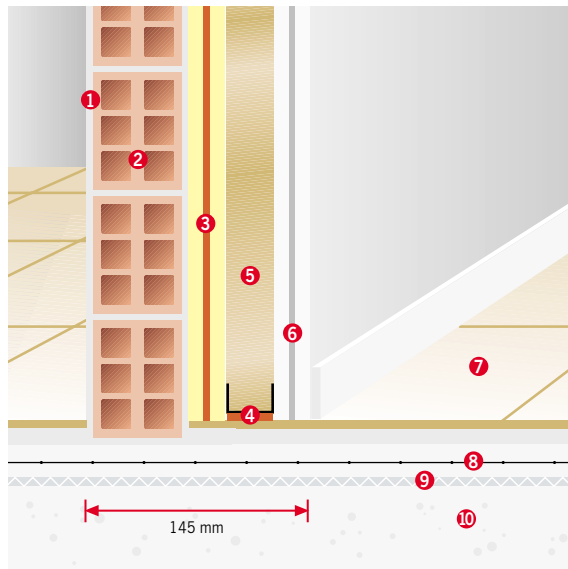

- | | |
|--|---------------------------------------|
| 1. Plaster coat | 6. 2 layers 13 mm gypsum plasterboard |
| 2. Double hollow brick (th: 7 cm) | 7. Flooring |
| 3. TECSOUND® 2FT 45 | 8. Reinforced mortar |
| 4. TECSOUND® SY BANDA 50 | 9. TEXSILEN |
| 5. Fibreglass (th: 50 mm; $d: 15 \text{ kg/m}^3$) | 10. Framework |

Fitting TECSOUND®

- TECSOUND® 2FT 45.
TECSOUND® 2FT 45 should be fitted according to the following steps:
 - 1) Make sure the support is clean, dry and preferably plastered. For restoration work, a check should be made that the plaster coat is in good condition and, in particular, that its surface is compact and even. Otherwise, the surface should be repaired before applying the LS ADHESIVE.
 - 2) Apply LS ADHESIVE with a short-nap roller over the partition and to the TECSOUND® 2FT 45 felt. Wait for 15-20 minutes.
 - 3) Line the TECSOUND® 2FT 45 up over the support and put in place. Make sure that the product is properly in contact with the top and bottom framework.
- TECSOUND® SY BANDA 50.
Before installing the metal structure, TECSOUND® SY BANDA 50 should be adhered to it and throughout the perimeter, in the area in contact with the support.

Join with ceiling

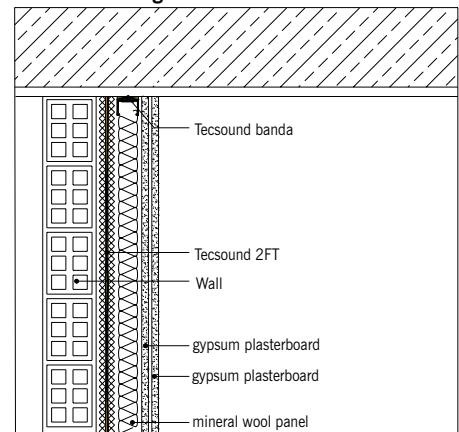

Join with floor

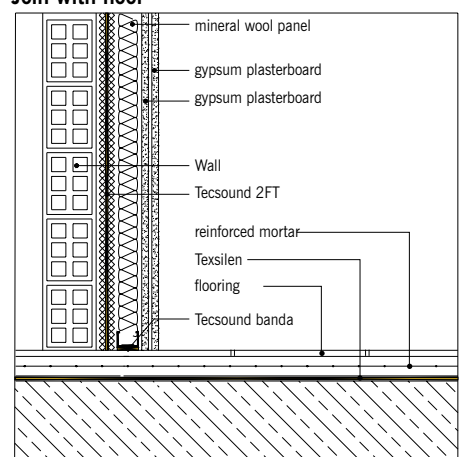

Comparative acoustic insulation graph

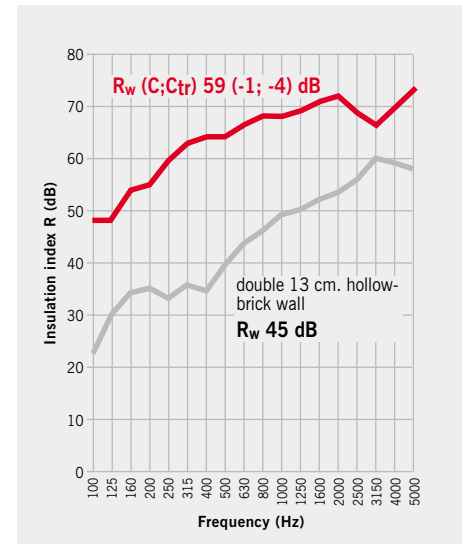

— LGAI (Spain) n° 20,009,301

— LGAI (Spain) n° 20,010,944

Freq.(Hz)	125	250	500	1000	2000	4000
— R (dB)	42.0	52.0	56.0	59.5	63.0	61.0
— R (dB)	30.0	33.0	39.5	49.0	53.5	59.0

Structural double hollow-brick wall rendered on the outside and inside, by application of 46 mm structure, rock wool panel with $d: 40 \text{ kg/m}^3$ inside, TECSOUND® SY 70 and double layer of sheet plaster 13 mm thick.

R_w 55 dB

Structural wall system designed for restoration of residential spaces. The system comprises a structural wall of 2 layers of sheet plaster plus TECSOUND® SY 70 fitted with metal structure work. The system offers good performance characteristics in a very reduced thickness.

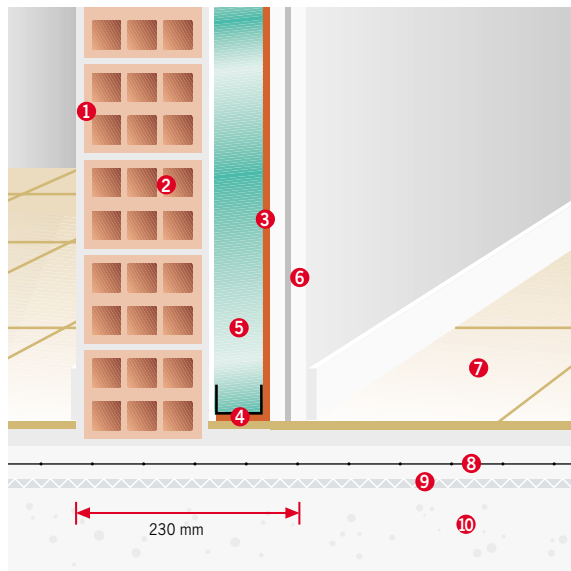

- | | |
|--|----------------------|
| 1. Plaster coat | 7. Flooring |
| 2. Double hollow brick (th. 14 cm) | 8. Reinforced mortar |
| 3. TECSOUND® SY 70 | 9. TEXSILEN |
| 4. TECSOUND® SY BANDA 50 | 10. Framework |
| 5. Rock wool (th: 50 mm; d: 40 kg/m ³) | |
| 6. 2 layers 13 mm gypsum plasterboard | |

Fitting TECSOUND®

- TECSOUND® SY BANDA 50.
Before installing the metal structure, TECSOUND® SY BANDA 50 should be adhered to it and throughout the perimeter, in the area in contact with the support.
- TECSOUND® SY 70.
The TECSOUND® SY 70 should be fitted to the plaster sheet as follows:
 - Lay a plaster sheet horizontally over trestle tables.
 - Lay the roll of TECSOUND® SY 70 over the plaster sheet so that the width matches that of the roll, ensuring that 1 cm of membrane protrudes at each side.
 - Pull out the roll, gradually peeling away the protective silicon-coated paper. Check the membrane is parallel to the sheet at all times. Continue the operation until the entire surface of the sheet is covered.
 - Trim any excess material.
 - Fit the sheet with TECSOUND® SY 70 so that the membranes are installed between one sheet and the structure work.

Join with ceiling

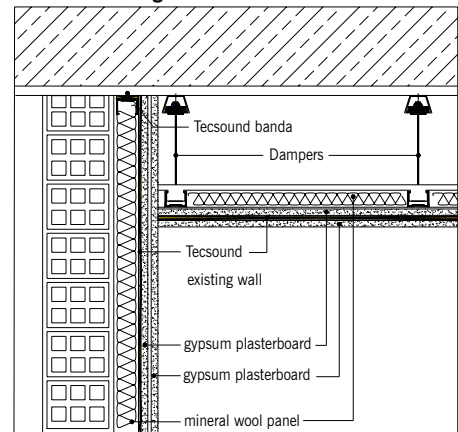

Join with floor

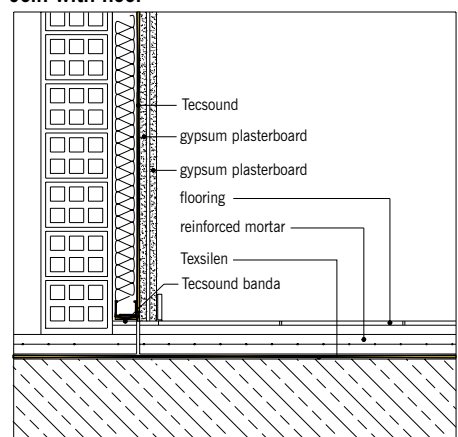

Comparative acoustic insulation graph

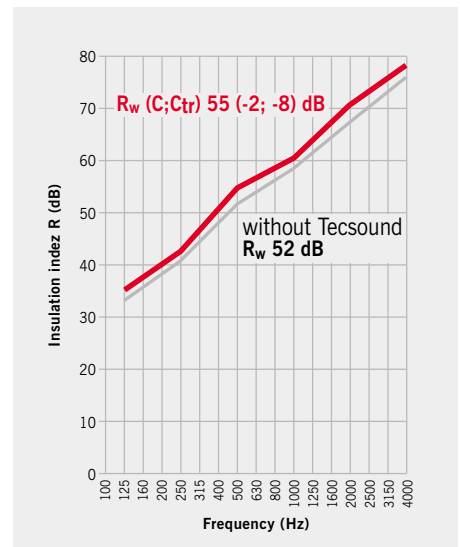

— Estudi Acústic H. Arau (Spain)

— Estudi Acústic H. Arau (Spain)

Freq.(Hz)	125	250	500	1000	2000	4000
— R (dB)	35.0	42.7	54.3	60.6	70.3	78.8
— R (dB)	33.2	40.6	52.0	58.3	67.9	76.5

This test was conducted with a numerical calculation value which gives a very close result to the actual insulation value.

Ceiling acoustic insulation system comprising structure suspended from dampers, rock wool panel with $d: 60 \text{ kg/m}^3$, TECSOUND® SY 70 installed between the two layers of sheet plaster 13 mm thick. Façade / front acoustic insulation system comprising double hollow brick rendered on the outside and application of 46 mm structural wall, rock wool panel with $d: 40 \text{ kg/m}^3$ inside, TECSOUND® SY 70 and double layer of sheet plaster 13 mm thick.

R_w Ceiling 51 dB

R_w Façade 55 dB

Acoustic false ceiling system recommended when there is little space in terms of height. It comprises an acoustic sandwich incorporating TECSOUND® SY 70 between two layers of sheet plaster and an absorbent material such as mineral wool to fill the air chamber. Using dampers attaches the false ceiling elastically to the framework, reducing transmission of vibrations.

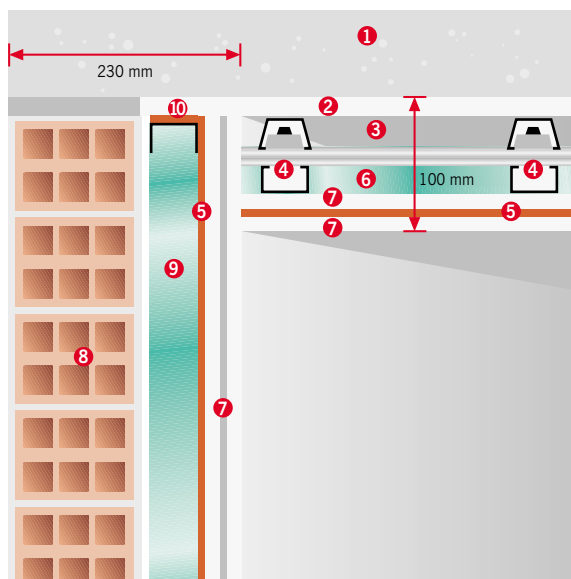

1. Framework
2. Plaster coat
3. Air chamber (th: 50 mm)
4. Dampers
5. TECSOUND® SY 70
6. Rock wool (th: 50 mm; $d: 60 \text{ kg/m}^3$)
7. 2 layers 13 mm gypsum plasterboard.
8. Double hollow brick (th: 14 cm)
9. Rock wool (th: 50 mm; $d: 40 \text{ Kg/m}^3$)
10. TECSOUND® BANDA

Fitting TECSOUND®

1. TECSOUND® SY 70.
The TECSOUND® SY 70 should be fitted to the plaster sheet as follows:
 - 1) Make sure the framework plaster is in good condition, and, in particular, that its surface is compact and even. Otherwise, the surface should be repaired before installing the false ceiling.
 - 2) Lay a sheet of plaster horizontally over trestle tables.
 - 3) Lay the roll of TECSOUND® SY 70 over the plaster sheet so that the width matches that of the roll, ensuring that 1 cm of membrane protrudes at each side.
 - 4) Pull out the roll, gradually peeling away the protective silicon-coated paper. Check the membrane is parallel to the sheet at all times. Continue the operation until the entire surface of the sheet is covered.
 - 5) Trim any excess material.
 - 6) Fit the sheet with TECSOUND® SY 70 so that the membranes are installed between one sheet and the structure work.

Join with ceiling

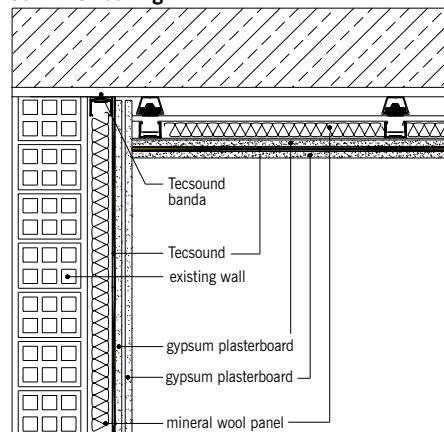

Join with floor

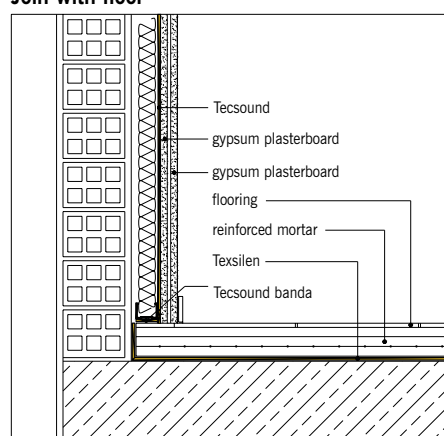

Comparative acoustic insulation graph in ceiling

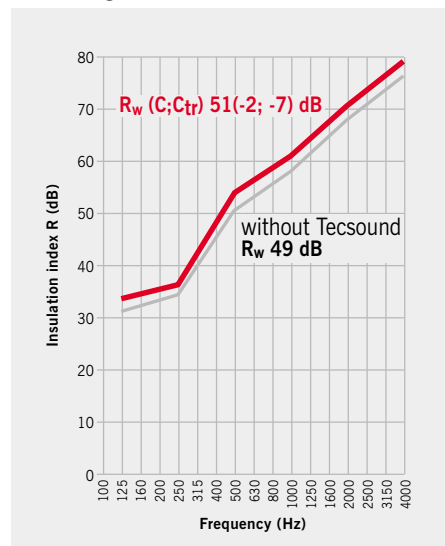

— Estudi Acústic H. Arau (Spain)
— Estudi Acústic H. Arau (Spain)

Freq.(Hz)	125	250	500	1000	2000	4000
R (dB)	33.3	37.1	53.1	60.9	70.7	79.7
R (dB)	31.4	34.9	50.8	58.5	68.4	77.4

This test was conducted with a numerical calculation value which gives a very close result to the actual insulation value.

Façade and ceiling insulation system. The false ceiling comprises **TECSOUND® FT 75**, 20 cm air chamber, structure suspended from dampers, rock wool panel with $d: 60 \text{ kg/m}^3$, **TECSOUND® SY 70** installed between the two layers of sheet plaster 13 mm thick. Façade / front acoustic insulation system comprising double hollow brick rendered on the outside and application of 46 mm structural wall, rock wool panel with $d: 40 \text{ kg/m}^3$ inside, **TECSOUND® SY 70** and double layer of sheet plaster 13 mm thick.

R_w Ceiling 56 dB

R_w Façade 55 dB

High performance false ceiling system. It comprises an acoustic sandwich incorporating **TECSOUND® SY 70** between two layers of sheet plaster and the **TECSOUND® FT 75** acoustic complex adhered to the framework. The air chamber enables utility installations to be passed through.

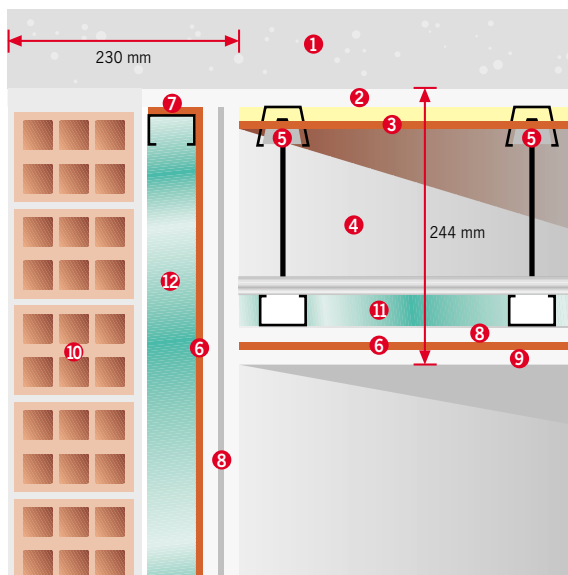

- | | |
|---------------------------|--|
| 1. Framework | 7. TECSOUND® SY BANDA 50 |
| 2. Plaster coat | 8. Layer standard gypsum plasterboard |
| 3. TECSOUND® FT 75 | 9. Layer absorbent gypsum plasterboard |
| 4. Air chamber | 10. Double hollow brick (th: 14 cm) |
| 5. Dampers | 11. Rock wool (th: 50 mm; d: 60 Kg/m³) |
| 6. TECSOUND® SY 70 | 12. Rock wool (th: 50 mm; d: 40 Kg/m³) |

Fitting **TECSOUND®**

- TECSOUND® FT 75.**
The **TECSOUND® FT 75** should be fitted as follows:
 - Check the framework plaster is in good condition, and, in particular, that its surface is compact and even. Otherwise, the surface should be repaired before installing the false ceiling.
 - Apply LS Adhesive with a short-nap roller over the plaster coat and to the **TECSOUND® 2FT 45** felt. Wait for 15-20 minutes.
 - Adhere **TECSOUND® FT 75** to the framework and attach using PVC rosettes with washer (5 per m²).
- TECSOUND® SY 70.**
The **TECSOUND® SY 70** should be fitted to the plaster sheet as follows:
 - Lay a sheet of plaster horizontally over trestle tables.
 - Lay the roll of **TECSOUND® SY 70** over the plaster sheet so that the width matches that of the roll, ensuring that 1 cm of membrane protrudes at each side.
 - Pull out the roll, gradually peeling away the protective silicon-coated paper. Check the membrane is parallel to the sheet at all times. Continue the operation until the entire surface of the sheet is covered.
 - Trim any excess material.
 - Fit the sheets with **TECSOUND® SY 70** adhered so that the membrane is installed between one sheet and the structure work.

Join with ceiling

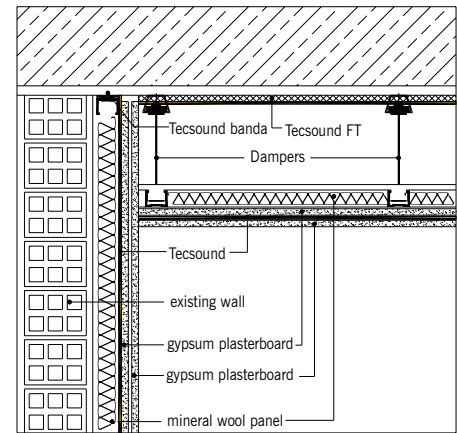

Join with floor

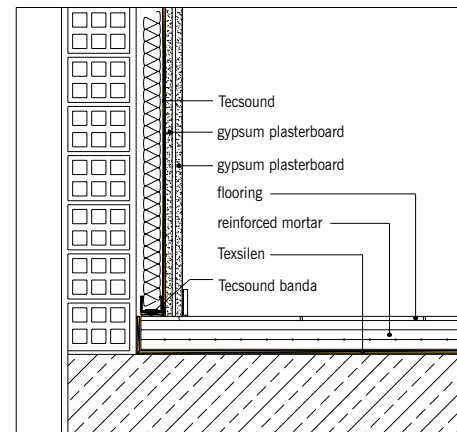

Comparative acoustic insulation graph

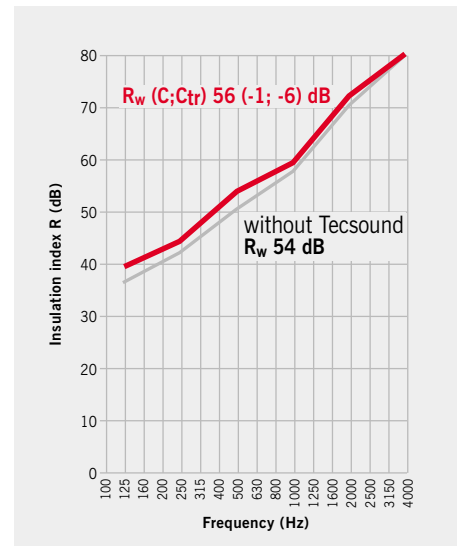

- Estudi Acústic H. Arau (Spain)
- Estudi Acústic H. Arau (Spain)

Freq.(Hz)	125	250	500	1000	2000	4000
— R (dB)	39.6	44.5	53.1	59.8	72.6	85.5
— R (dB)	37.6	42.2	50.8	57.5	70.3	83.1

This test was conducted with a numerical calculation value which gives a very close result to the actual insulation value.

Impact noise acoustic insulation system by installation of TEXSILEN 5 MM membrane over the framework, layer of mortar and flooring.

ΔL_w 20 dB

The proposed solution comprises a layer of TEXSILEN 5 MM positioned between the framework and the compression layer. This system enables the NBE-88 standard to be met, using an economical material which is easy to install.

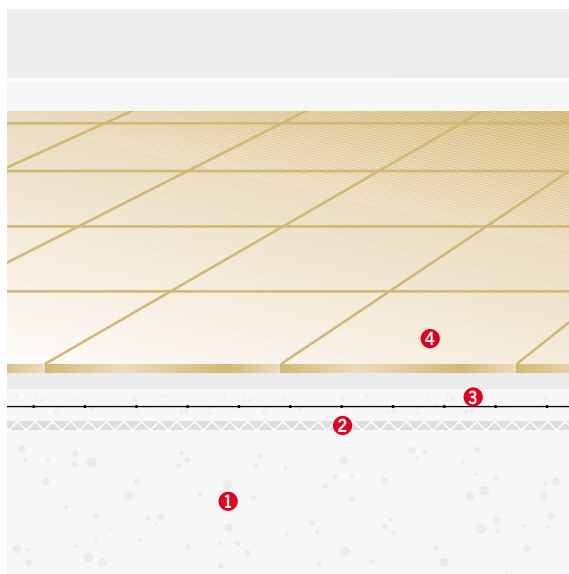

- 1. Framework
- 2. TEXSILEN 5MM
- 3. Reinforced mortar
- 4. Flooring

Join with wall

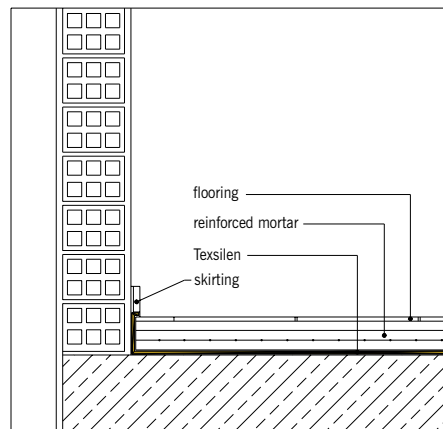

General close-up

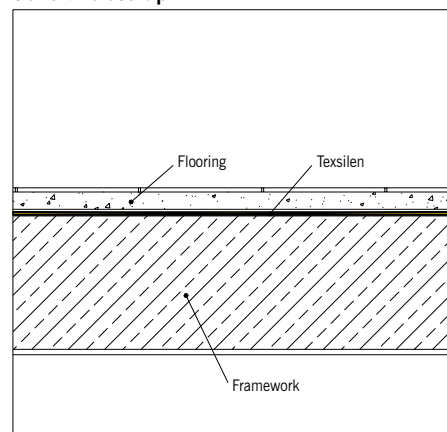

Fitting TEXSILEN 5MM

1. TEXSILEN 5 MM.

The TEXSILEN 5 MM should be fitted as follows:

- 1) Check the surface of the framework is even and free from elements which could damage the TEXSILEN while it is being installed.
- 2) Pull out the reels of TEXSILEN 5 MM over the framework, overlapping 8 cm as it becomes necessary.
- 3) Bring the TEXSILEN 5 MM up against the vertical surfaces, raising it approximately 10/15 cm above the framework.
- 4) Once installation of the TEXSILEN 5 MM is complete, the compression layer of reinforced mortar should be laid as a support for the flooring. It is advisable to seal overlaps with adhesive tape, to prevent moisture filtration from the water content in the mortar.
- 5) Trim any excess TEXSILEN 5 MM protruding along the vertical surfaces.

Improvement impact noise insulation

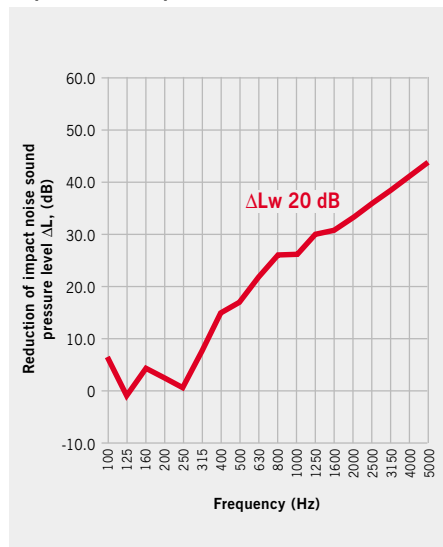

— LGAI (Spain) nº 22,012,881

Freq.(Hz)	125	250	500	1000	2000	4000
ΔL (dB)	-1.1	0.4	17.9	27.0	33.0	41.0

Impact noise acoustic insulation system by installation of TEXSILEN 10 MM membrane over the framework, layer of mortar and flooring.

ΔL_w 19 dB

The proposed solution comprises a layer of TEXSILEN 10 MM positioned between the framework and the compression layer. We recommend installing TEXSILEN 10 MM when higher crushing strength is required.

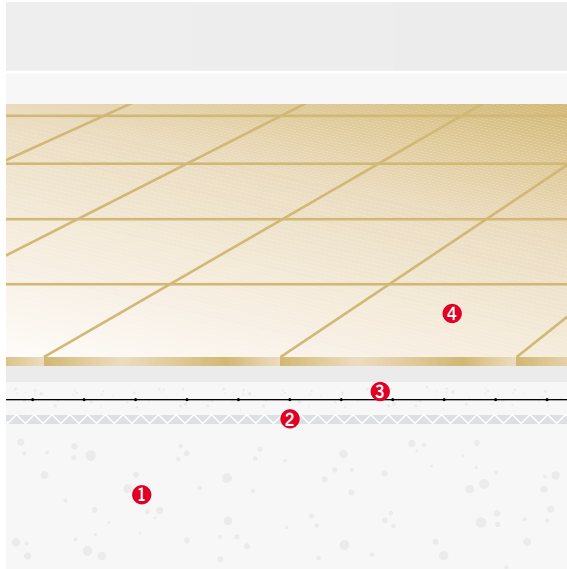

1. Framework
2. TEXSILEN 10MM
3. Reinforced mortar
4. Flooring

Join with wall

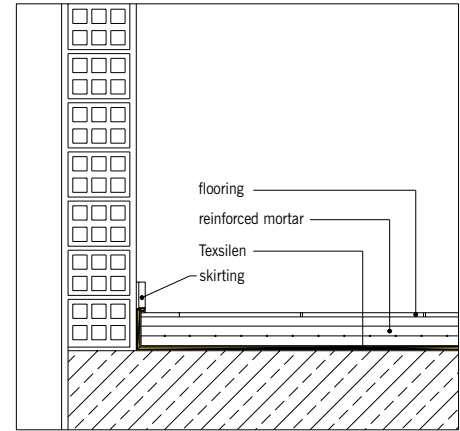

General close-up

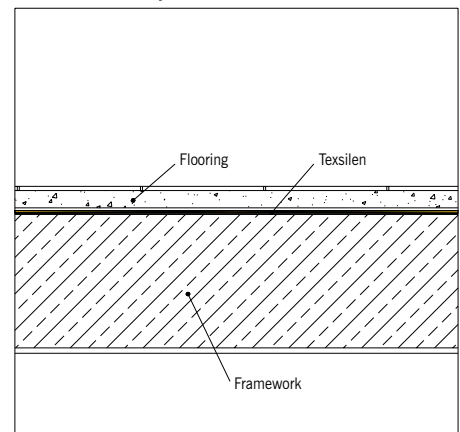

Improvement to impact noise insulation

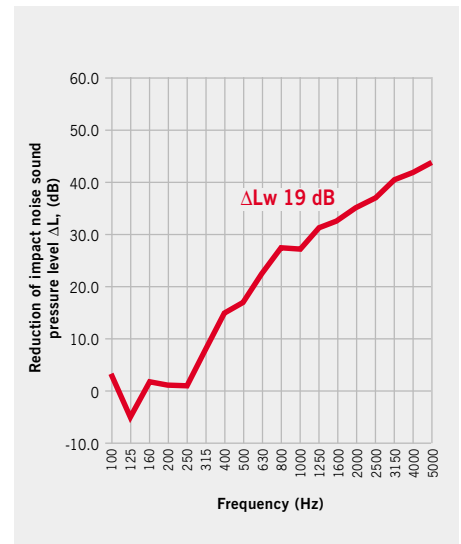

— LGAI (Spain) n° 22,012,882

Freq.(Hz)	125	250	500	1000	2000	4000
ΔL (dB)	-5.4	1.5	17.9	28.1	35.2	41.9

Impact noise acoustic insulation system by installation over the framework of TECSOUND® 70, TEXSILEN 5 MM membrane, and floating parquet flooring.

The standard solution comprises an expanded polyethylene membrane between the framework and the floating parquet. This solution does not eliminate the airborne noise caused by footsteps typical of parquet floors. An enhanced solution is to fit TECSOUND® 70 membrane between the finish and TEXSILEN 5 MM, as is demonstrated by the results of the in situ studies.

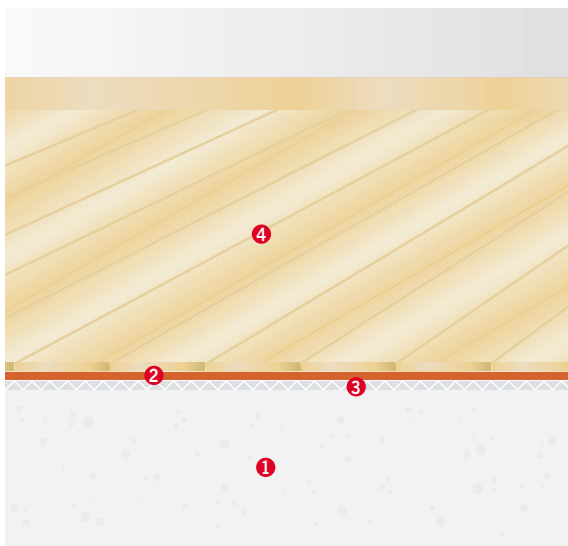

- 1. Framework
- 2. TECSOUND® 70
- 3. TEXSILEN 5MM
- 4. Parquet floor

Join with wall

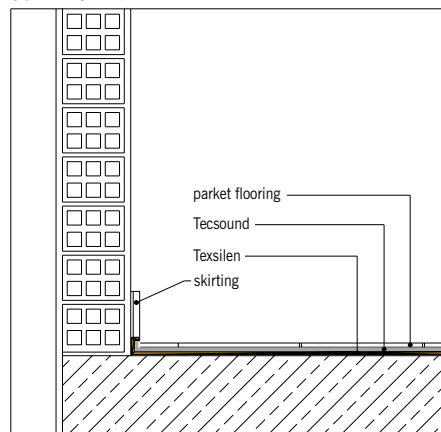

General close-up

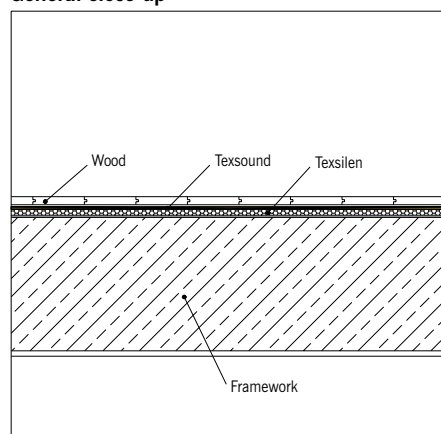

Fitting TECSOUND® and TEXSILEN

1. TEXSILEN 5 MM.
The TEXSILEN 5 MM should be fitted as follows:
 - 1) Check the surface of the framework is even, smooth and free from elements which could damage the TEXSILEN 5 MM while it is being installed.
 - 2) Pull out the sheets of TEXSILEN 5 MM over the framework, overlapping 8 cm as it becomes necessary.
 - 3) Bring the TEXSILEN 5 MM up against the vertical surfaces, raising it approximately 10 cm.
2. TECSOUND® 70.
Once installation of the TEXSILEN is complete, TECSOUND® 70 should be fitted as follows:
 - 1) Pull out the rolls of TECSOUND® 70 making "a testa" joints between the side edges.
 - 2) Bring the TECSOUND® 70 up against the vertical surfaces, raising it approximately 10 cm.
 - 3) Immediately afterwards, lay the parquet flooring so that it is resting on top of the TECSOUND® 70. Trim the excess TECSOUND® 70 and TEXSILEN 5 MM protruding along the vertical surfaces.

Reduction of the airborne noise level produced by impacts on floating parquet flooring

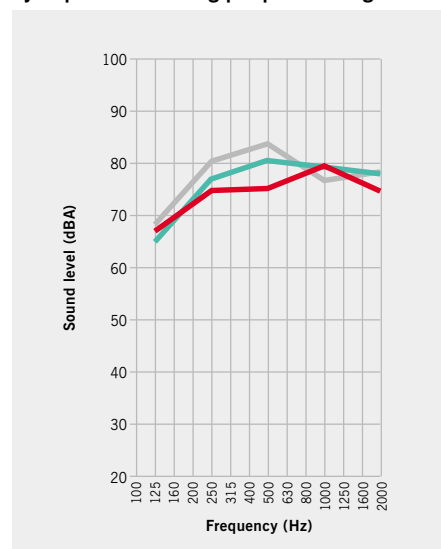

Measurement in situ

- Flooring
- Parquet + TEXSILEN 5MM
- Parquet + TECSOUND® 70 + TEXSILEN 5MM

Freq.(Hz)	125	250	500	1000	2000
— (dBA)	65.1	77.1	80.3	79.2	78.6
— (dBA)	68.5	80.8	83.2	77.6	78.8
— (dBA)	67.8	74.9	75.3	79.1	74.7

System comprising one or more layers of **TECSOUND® FT 55 AL** fitted around the drainpipe.

R_w 25 dB

The noise caused by discharging fluids in drainpipes is one of the commonest problems in residential and office buildings, due to the low acoustic insulation provided by standard pipes built into walls and false ceilings. In one single product, **TECSOUND® FT 55 AL** gives you an absorbent material and a **TECSOUND®** insulating membrane, with the characteristics needed to provide an answer to this problem.

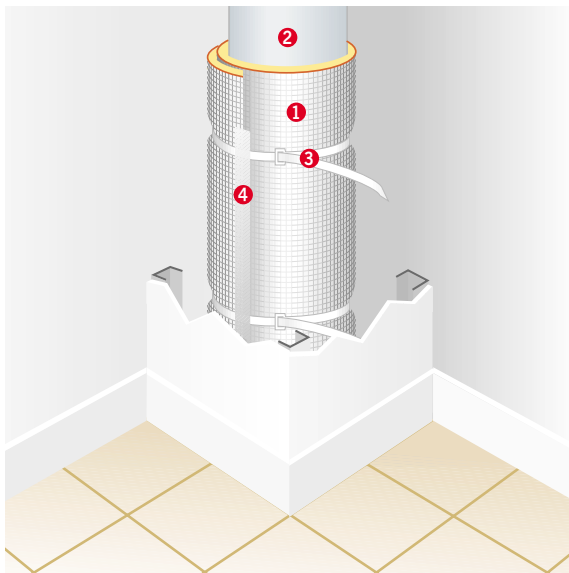

- 1. **TECSOUND® FT 55 AL**
- 2. PVC drainpipe
- 3. Plastic flange
- 4. Aluminium tape

General close-up

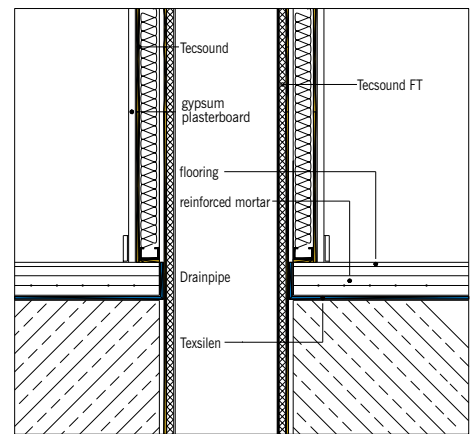

Suspended installations

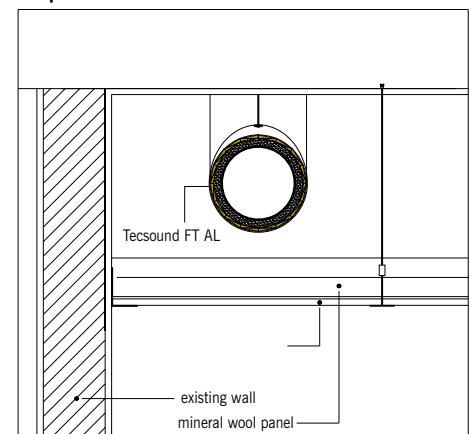

Comparative acoustic insulation graph

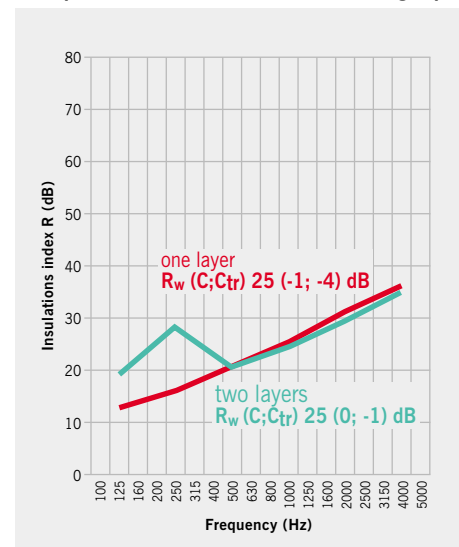

— Estudi Acústic H. Arau (Spain)

— Estudi Acústic H. Arau (Spain)

Freq.(Hz)	125	250	500	1000	2000	4000
— R (dB)	12.1	16.0	20.6	25.7	30.9	36.3
— R (dB)	19.7	28.5	20.0	24.4	29.1	34.1

This test was conducted with a numerical calculation value which gives a very close result to the actual insulation value.

R_w 36 dB

Innovative acoustic and thermal insulation system for metal roofs, for large surface areas and shopping centres. TECSOUND® 50 AL acts as a damping element against vibrations, and also as a vapour barrier. AISLADECK BV, the new thermal insulator specially designed for metal roofs, guarantees excellent performance against transmission of heat. Thanks to its bitumen finish, the waterproofing membrane can be fired straight onto its surface.

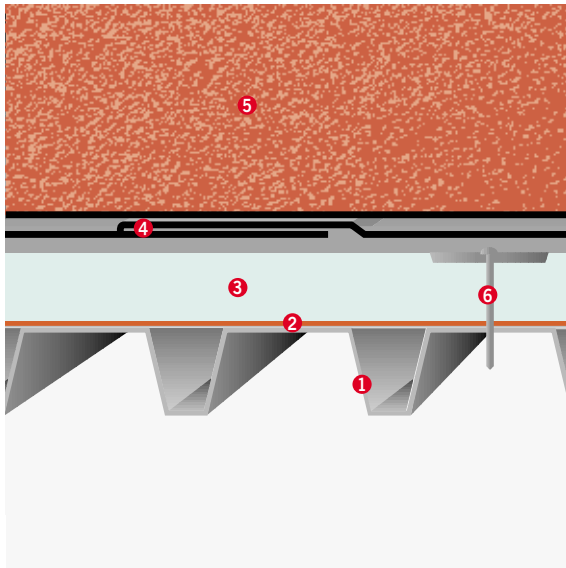

- 1. Fretwork sheet (th: 0,7 mm)
- 2. TECSOUND® 50 AL
- 3. AISLADECK BV
- 4. MORTERPLAS FV 3 Kg
- 5. MORTERPLAS SBS FPV Mineral 4.8 kg
- 6. Mechanical attachment

Fitting TECSOUND®

1. TECSOUND® 50 AL.

The TECSOUND® 50 AL is fitted as follows:

- 1) Once the fretwork sheet has been installed, spread TECSOUND® 50 AL over the entire surface of the roof so that the aluminium face is in contact with the metal plate, leaving 5 cm overlaps, which should be adhered with contact glue.
- 2) Once this is complete, fit the sheets of AISLADECK BV and then the waterproofing membranes MORTERPLAS FV 3 kg and MORTERPLAS SBS FPV Mineral 4.8 kg.

General close-up

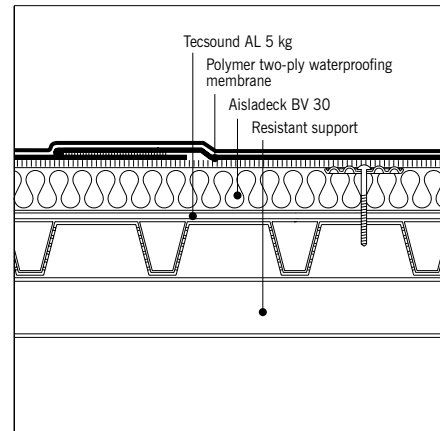

Comparative acoustic insulation graph

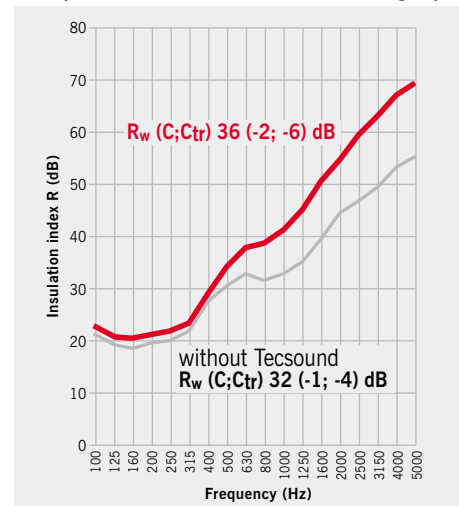

- SRL (UK) N° C/00/5L/7950/2-6
- SRL (UK) N° C/00/5L/7950/2-5

Freq.(Hz)	125	250	500	1000	2000	4000
— R (dB)	21.0	22.0	32.4	41.1	53.6	65.7
— R (dB)	19.3	20.6	29.7	32.8	42.8	52.1

Enhancement of impact noise insulation

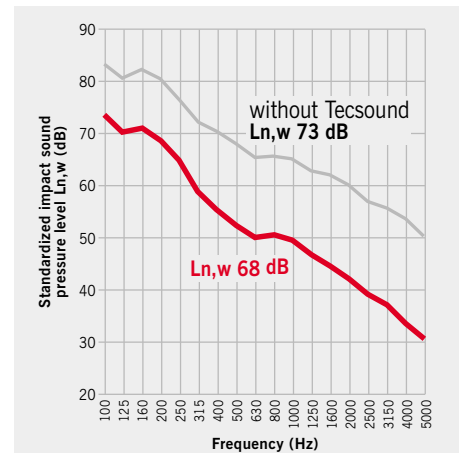

- SRL (UK) N° C/00/5L/7950/2-12
- SRL (UK) N° C/00/5L/7950/2-14

Freq.(Hz)	125	250	500	1000	2000	4000
— Ln (dB)	82.7	76.7	64.3	59.4	53.4	45.3
— Ln (dB)	86.9	82.1	73.0	69.6	64.8	58.6

R_w 39 dB

Traditional metal roof system with built-in mineral wool panels as thermal insulation. Installing TECSOUND® 50 AL gives the system mass and reduces the vibrations of the metal plate.

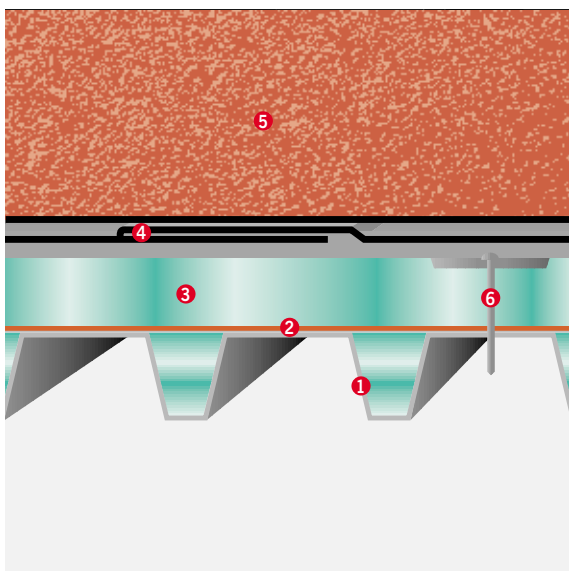

1. Fretwork sheet (th: 0.7 mm)
2. TECSOUND® 50 AL
3. ROCK WOOL (th: 80 mm; d: 150 Kg/m³)
4. MORTERPLAS FV 3 Kg Mineral 4.8 kg
5. MORTERPLAS SBS FPV Mineral 4.8 kg
6. Mechanical attachment

General close-up

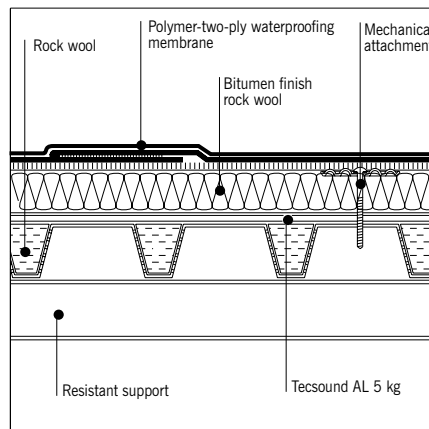

Comparative acoustic insulation graph

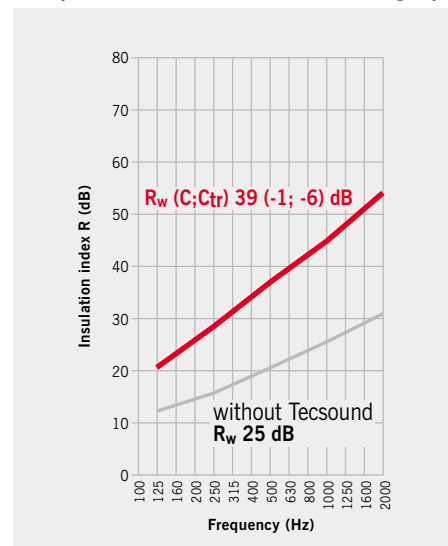

— Estudi Acústic H. Arau (Spain)

— Estudi Acústic H. Arau (Spain)

Freq.(Hz)	125	250	500	1000	2000
R (dB)	20.5	28.1	37.4	44.9	53.6
R (dB)	12.1	16.0	20.6	25.7	30.9

This test was conducted with a numerical calculation value which gives a very close result to the actual insulation value.

R_w 50 dB

Acoustic insulation system for pitched roofs with low thermal inertia, comprising inner timbered finish, TECSOUND® SY 70, WALLMATE CW thermal insulating layer, ventilation chamber, TECSOUND® FT 75, spruce board supporting TEGOLA CANADESE shingles or slate.

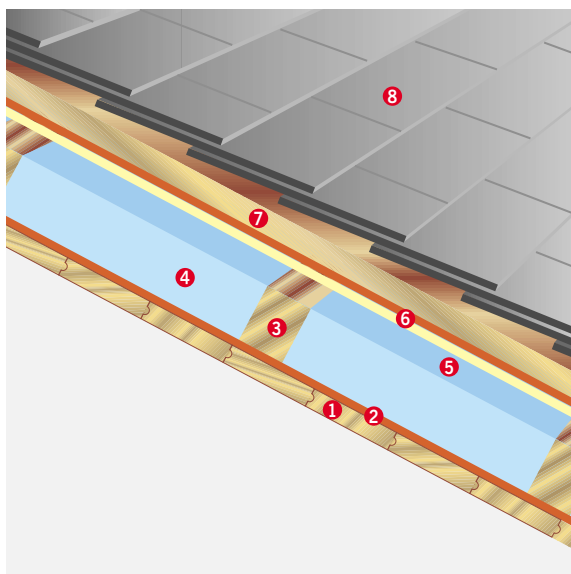

- | | |
|---------------------------------|--------------------|
| 1. Wooden tonguing and grooving | 5. Air chamber |
| 2. TECSOUND® SY 70 | 6. TECSOUND® FT 75 |
| 3. Footing pieces | 7. Support |
| 4. WALLMATE CW | 8. TEGOLA CANADESE |

General close-up

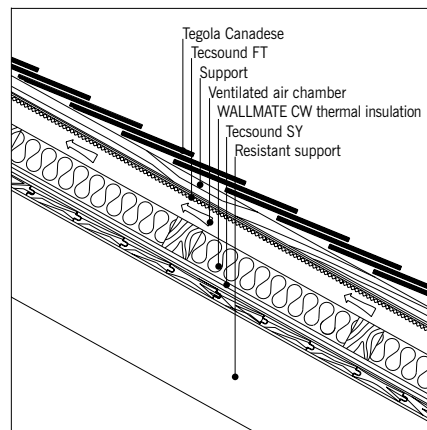

Comparative acoustic insulation graph

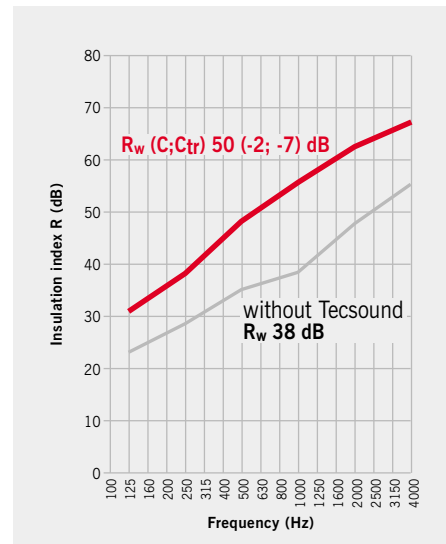

Fitting TECSOUND®

- TECSOUND® SY 70.
The TECSOUND® SY 70 should be fitted as follows:
 - Fit TECSOUND® SY 70 over the wooden tongue and groove system, gradually peeling away the silicon-coated paper and pressing down for perfect adhesion, overlapping a width of 5 cm.
 - Trim any excess material.
- TECSOUND® FT 75.
The TECSOUND® FT 75 should be fitted as follows:
 - Nail TECSOUND® FT 75 on the footing pieces forming the air chamber. Overlap the layers of TECSOUND® FT 75 so that the overlaps are down water.
 - Next, install the TEGOLA CANADESE support board.
TECSOUND® FT 75 can also be applied to the board before attaching it to the footing pieces, using LS ADHESIVE.

— Estudi Acústic H. Arau (Spain)
— Estudi Acústic H. Arau (Spain)

Freq.(Hz)	125	250	500	1000	2000	4000
R (dB)	31.0	38.8	48.2	55.9	62.6	67.9
R (dB)	22.8	28.8	35.1	38.1	47.9	55.4

This test was conducted with a numerical calculation value which gives a very close result to the actual insulation value.

R_w (shingles or mixed tiling) 51 dB

Acoustic insulation system for pitched roofs with low thermal inertia, comprising inner finish of double-layer sheet plaster 13 mm thick, TECSOUND SY 70, fibreglass thermal insulating layer, spruce board supporting attachment footing pieces of the mixed tiling.

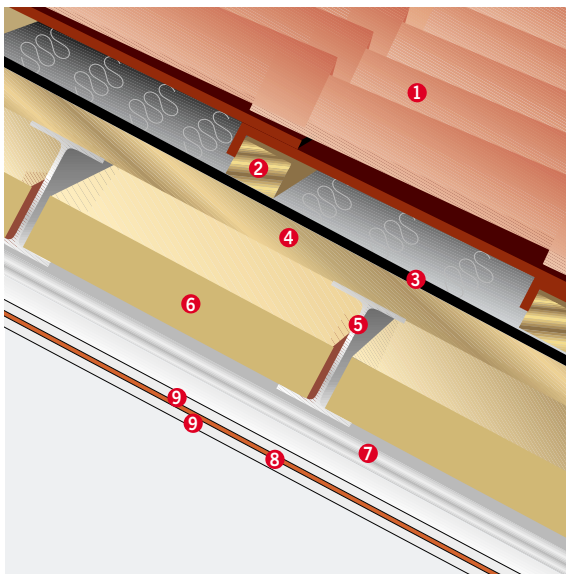

- | | |
|----------------------------|--|
| 1. Mixed tiling / shingles | 6. Fibreglass
(th: 10 cm; d: 15 Kg/m ³) |
| 2. Footing pieces | 7. Omega structures |
| 3. TEXSELF CI | 8. TECSOUND [®] SY 70 |
| 4. Plywood | 9. Gypsum plasterboard 13 mm thick. |
| 5. Metal beam | |

General close-up

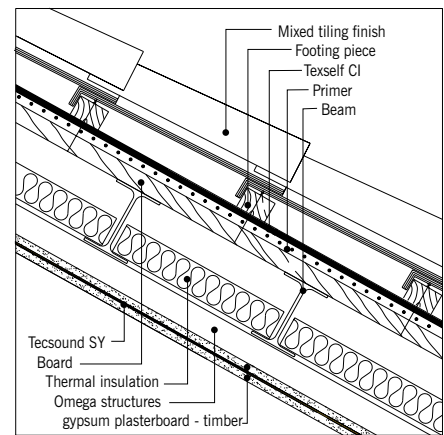

Comparative acoustic insulation graph

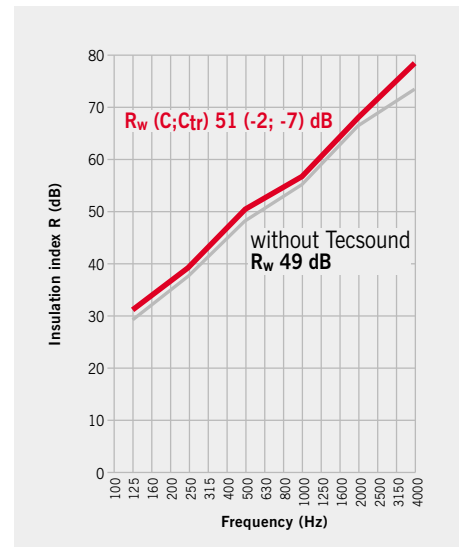

- Estudi Acústic H. Arau (Spain)
- Estudi Acústic H. Arau (Spain)

Freq.(Hz)	125	250	500	1000	2000	4000
R (dB)	31.2	39.7	50.4	57.6	68.5	76.0
R (dB)	29.8	37.8	48.4	55.2	66.5	73.2

This test was conducted with a numerical calculation value which gives a very close result to the actual insulation value.

Technical Data Sheets

TECSOUND® 35, 70, 100

TECSOUND® S 35, 70, 100

TECSOUND® SY 50, 70

TECSOUND® SY BANDA 50, 70

TECSOUND® FT 40, 75

TECSOUND® 2FT 45, 80

TECSOUND® FT 55 AL

TECSOUND® is a high-density, polymer-based, synthetic soundproofing membrane, asphalt-free, which provides good acoustic insulation in the different construction elements.

Standard

NBE-CA-88, (currently being revised).

Properties

- High acoustic insulation, combined with flexion-pliable elements (sheet plaster, carrier board).
- Flexible.
- High elongation capacity.
- Easy to handle and adaptable to uneven surfaces.
- Hot and cold-resistant.
- Self-extinguishing.
- Excellent ageing-resistance.
- Rot-proof.

Applications

- Airborne noise insulation in vertical surfaces with low surface mass (lightweight partitions or panels in various materials).
- Airborne noise insulation in ceilings.
- Reduction of impact noise level in all types of frameworks, in formation of floating floors.
- Damping of impact noise produced by atmospheric agents in metal roofs.
- In combination with sound-absorbent materials, it results in products with high acoustic performance characteristics.
- Its applications in the industrial sector range from soundproofing booths to insulation of machine rooms, drainpipes, acoustic damping of metal sheeting, etc.

For further information, see examples in the system data sheets.

Technical data

Test	Value
Density (g/cm ³)	1.90 ± 0.05
Pliability (UEAtc)	Does not break when bent at -20 °C
Tensile strength (UNE 104-281/6.6)	30 N/cm ²
Elongation (UNE 104-281/6.6)	300%
Crushing strength	4.84 Kg/cm ²
Acoustic properties	See system data sheets

Instructions for use

Support: Admits all habitual types of construction supports (sheet plaster, metal, carrier board, plastics). The support must be even, smooth, clean and dry. It must furthermore be dry and cleaned of any elements that could damage the membrane. If the plaster coat is old, its condition should be checked to prevent problems with adherence of the Tecsound to the plaster coat.

Fitting the membrane: The membrane is laid over the support after application of **LS Adhesive** to the membrane and the support, first leaving this to dry for 15-20 minutes before fitting.

Joins: Overlap 5 cm both vertically and horizontally. The precaution of sealing the joins correctly should always be taken, either with the adhesive or with hot air, as small openings can reduce the level of acoustic insulation required.

Quantity required: 1 m² of membrane covers approximately 0.90 m² of surface area, allowing for overlaps.

Presentation and storage

Type	kg/m ²	Thickness (mm)	Presentation	Nº of rolls-sheets / pallet
Tecsound 35	3.5	1.8	Rolls 6 x 1.05 m	22 rolls (138.6 m ²)
Tecsound 70	7	3.8	Sheets de 1.35 x 1.05 m Rolls de 5 x 1.05	100 pieces (142 m ²) 18 rolls (94.50 m ²)
Tecsound 100	10	5.3	Sheets 1.35 x 1.05 m	75 pieces (106.5 m ²)

It should be stored in a dry place, protected against the elements, and not exposed to temperatures over 35 °C.
The maximum recommended storage time is one year.

Auxiliary products

Type	Application	Approx. amount used	Presentation
Adhesivo LS	Adhesive for gluing the membrane to the surface	600 – 750 gr/m ²	25 Kg cans

TECSOUND® S is a high-density, polymer-based, synthetic soundproofing membrane, asphalt-free, which provides good acoustic insulation in the different construction elements. It has a built-in self-adhesive layer enabling it to be applied straight onto most construction surfaces.

Standard

NBE-CA-88, (currently being revised).

Properties

- High acoustic insulation, combined with flexion-pliable elements.
- Flexible.
- High elongation capacity.
- Easy to handle and adaptable to uneven surfaces.
- Hot and cold-resistant.
- Excellent adherence on all kinds of surfaces.
- Self-extinguishing.
- Excellent ageing-resistance.
- Rot-proof.

Applications

- Airborne noise insulation in vertical surfaces with low surface mass (lightweight partitions or panels in various materials).
- Airborne noise insulation in ceilings.
- Reduction of impact noise level in all types of frameworks, in formation of floating floors.
- Damping of impact noise produced by atmospheric agents in metal roofs.
- In combination with sound-absorbent materials, it results in products with high acoustic performance characteristics.
- Its applications in the industrial sector range from soundproofing booths to insulation of machine rooms, drainpipes, acoustic damping of metal sheeting, etc.
- Specially for plaster sheet measurements.

For further information, see examples in the system data sheets.

Technical data

Test	Value
Density	1.9 g/cm ²
Pliability (UEAtc)	Does not break when bent at -20 °C
Tensile strength (UNE 104-281/6.6)	30 N/cm ²
Elongation (UNE 104-281/6.6)	300%
Crushing strength	4.84 Kg/cm ²
Acoustic properties	See system data sheets

Instructions for use

Support: Admits all habitual types of construction supports (rendering, sheet plaster, metal, carrier board, plastics). The support must be even, smooth, clean and dry. It must furthermore be cleaned of any elements that could damage the membrane. If the plaster coat is old, its condition should be checked to prevent problems with adherence of the products to the plaster coat.

Fitting the membrane: The silicon-coated paper is peeled back and the membrane is lined up on the support, and then pressed down all over to ensure correct adherence. If the section of product is very large or it is applied rolled up, we recommend peeling the protective paper back gradually to make it easier to install.

Joins: Overlap 5 cm both vertically and horizontally. The precaution of sealing the joins correctly should always be taken, as small openings can reduce the level of acoustic insulation required.

Quantity required: 1 m² of membrane covers approximately 0.95 m² of surface area, allowing for overlaps.

Presentation and storage

Type	kg/m ²	Thickness (mm)	Presentation	N° of rolls-sheets / pallet
Tecsound S 35	3.5	1.8	Rolls of 6 x 1.0 m	22 rolls (132 m ²)
Tecsound S 70	7	3.8	Rolls of 5 x 1.0 m	18 rolls (90 m ²)
Tecsound S 100	10	5.3	Sheets 1.35 x 1.0 m	75 pieces (101.25 m ²)

It should be stored in a dry place, protected against the elements, and not exposed to temperatures over 35 °C. The maximum recommended storage time is one year.

TECSOUND® SY is a high-density, polymer-based, synthetic soundproofing membrane, asphalt-free, which provides good acoustic insulation in the different construction elements. It has a built-in self-adhesive layer enabling it to be applied straight onto most construction surfaces.

Standard

NBE-CA-88, (currently being revised).

Properties

- High acoustic insulation, combined with flexion-pliable elements.
- Flexible.
- High elongation capacity.
- Easy to handle and adaptable to uneven surfaces.
- Hot and cold-resistant.
- Excellent adherence on all kinds of surfaces.
- Self-extinguishing.
- Excelente resistencia al envejecimiento.
- Rot-proof.

Applications

- Airborne noise insulation in vertical surfaces with low surface mass (lightweight partitions or panels in various materials).
- Airborne noise insulation in ceilings.
- Reduction of impact noise level in all types of frameworks, in formation of floating floors.
- Damping of impact noise produced by atmospheric agents in metal roofs.
- In combination with sound-absorbent materials, it results in products with high acoustic performance characteristics.
- Its applications in the industrial sector range from soundproofing booths to insulation of machine rooms, drainpipes, acoustic damping of metal sheeting, etc.
- Specially for plaster sheet measurements.

For further information, see examples in the system data sheets.

Technical data

Test	Value
Density	1.9 g/cm ²
Pliability (UEAtc)	Does not break when bent at -20 °C
Tensile strength (UNE 104-281/6.6)	30 N/cm ²
Elongation (UNE 104-281/6.6)	300%
Crushing strength	4.84 Kg/cm ²
Acoustic properties	See system data sheets

Intructions for use

Support: Admits all habitual types of construction supports (rendering, sheet plaster, metal, carrier board, plastics). The support must be even, smooth, clean and dry. It must furthermore be free from any elements that could damage the membrane. If the plaster coat is old, its condition should be checked to prevent problems with adherence of the product to the plaster coat.

Fitting the membrane: The silicon-coated paper is peeled back and the membrane is lined up on the support, and then pressed down all over to ensure correct adherence. If the section of product is very large or it is applied rolled up, we recommend peeling the protective paper back gradually to make it easier to install.

Joins: Overlap 5 cm both vertically and horizontally. The precaution of sealing the joins correctly should always be taken, as small openings can reduce the level of acoustic insulation required.

Quantity required: 1 m² of membrane covers approximately 0.95 m² of surface area, allowing for overlaps.

Presentation and storage

Type	kg/m ²	Thickness (mm)	Presentation	Nº de rolls-sheets / pallet
Tecsound SY 50	5	2.6	Rolls of 6.05 x 1.22	21 rolls (155 m ²)
Tecsound SY 70	7	3.7	Rolls of 5.05 x 1.22	25 rolls (154 m ²)

It should be stored in a dry place, protected against the elements, and not exposed to temperatures over 35 °C. The maximum recommended storage time is one year.

TECSOUND® SY BANDA is a high-density, polymer-based, synthetic TECSOUND membrane soundproofing tape, asphalt-free, with a built-in self-adhesive layer enabling it to be applied straight onto metal structures subject to vibrations.

Properties

- High damping power on metal surfaces and structures.
- High flexibility.
- High elongation capacity.
- Easy to handle and adaptable to uneven surfaces.
- Waterproof. High resistance to water vapour.
- Excellent ageing-resistance.

Applications

- Disconnection of the base support structure from the rest of the structure.
- Damping of vibrations in metal roofs, between the plate and the structure.

Technical data

Test	Value
Density	1.9 g/cm ³
Pliability (UEAtc)	Does not break when bent at -10 °C
Tensile strength (UNE 104-281/6.6)	30 N/cm ²
Elongation (UNE 104-281/6.6)	300%
Crushing strength	4.84 Kg/cm ²

Instructions for use

Support: The support surface must be free from grease and dust.

Installation on dry partitions: Adhere TECSOUND SY BANDA to the outer surface of the structure work (surface in contact with the construction), gradually peeling back the protective silicon-coated paper to ensure good adherence.

Attach the channels to the support. Next, fit the plaster sheets in the structure, according to the manufacturer's instructions.

Installation on metal roofs: Adhere TECSOUND SY BANDA to the surface of the metal strip in contact with the fretwork sheet, gradually peeling back the protective silicon-coated paper and pressing down to ensure good adherence. Next, fit the fretwork sheet.

Presentation and storage

Product	Width (mm)	Length (m)	Thickness (mm)	Tapes/box (pieces)	linear metres box
TECSOUND SY BANDA-50	50	6	2.6	12	72
TECSOUND SY BANDA-70	70	6	2.6	8	48

The product should be stored in a dry place, protected against the elements, and not exposed to temperatures over 35 °C. The maximum recommended storage time is one year.

TECSOUND® FT is a soundproofing complex comprising a porous felt and the polymer-based Tecsound synthetic membrane, asphalt-free, both formed so that they provide high acoustic insulation in the different construction elements: walls, ceilings, roofs, etc.

Standard

NBE-CA-88, (currently being revised).

Properties

- High acoustic insulation, combined with flexion-pliable elements (sheet plaster, carrier board).
- Easy handling and application.
- Joins easy to execute.
- Excellent ageing-resistance.
- Rot-proof.
- Self-extinguishing.
- Hot and cold-resistant.

Applications

Soundproofing of horizontal (ceilings) and vertical enclosures, where high acoustic insulation against transmission of airborne noise is required.

- Airborne noise insulation in vertical surfaces.
- Airborne noise insulation in ceilings.
- Reduction of impact noise level in all types of frameworks and crossbeams.

Its main applications include new construction and restoration works, industries, cinemas, theatres, sports complexes, night clubs, bars, restaurants, hotels, shopping centres,

For further information, see the system data sheets.

Technical data

Test	Value
Tensile strength (UNE 104-281/6.6)	> 30 N/cm ² (Tecsound membrane)
Thermal conductivity coefficient	0.037 W/m·°C (felt)
Acoustic properties	See construction solution data sheets

Instructions for use

Support: Admits all habitual types of construction supports. The support must be even, clean, dry and preferably plastered. If the plaster coat is old, its condition should be checked to prevent problems with adherence of the Tecsound FT to it.

Fitting: Apply LS Adhesive to the support and the panel on the felt side. Leave to dry for 15-20 minutes. Line the Tecsound FT up with the support along the felt side and fit in place.

Overlaps: The panel has a 5 cm overlap on two consecutive sides. The overlaps should be sealed with hot air or using the adhesive. The precaution of sealing the joins correctly should always be taken, as small openings can considerably reduce the acoustic insulation effect.

Presentation and storage

Type	kg/m ²	Thickness (mm)	Presentation	Pieces / pallet
Tecsound FT 40	4.1	12	Rolls 6 x 1.05 m	6 rolls (63 m ²)
Tecsound FT 75	7.6	14	Sheets 1.35 x 1.05 m	25 pieces (35.44 m ²)

The product should be stored in a dry place, protected against the elements, and not exposed to temperatures over 35 °C. The maximum recommended storage time is one year.

Auxiliary products

Type	Application	Approx. amount used	Presentation
Adhesivo LS	Adhesive for gluing Tecsound FT to the surfaces	600 – 750 gr/m ²	25 kg cans

TECSOUND® 2FT is a soundproofing complex comprising two porous felts with the polymer-based Tecsound synthetic membrane, asphalt-free, sandwiched in between, so that they provide excellent acoustic insulation in the different construction elements: walls, ceilings, roofs, etc.

Standard

NBE-CA-88, (currently being revised).

Properties

- High acoustic insulation, combined with flexion-pliable elements (sheet plaster, carrier board).
- Easy handling and application.
- Joins easy to execute.
- Excellent ageing-resistance.
- Rot-proof.
- Self-extinguishing.
- Hot and cold-resistant.

Applications

Soundproofing of horizontal (ceilings) and vertical enclosures, where excellent acoustic insulation against transmission of airborne noise is required.

- Specially recommended in partition walls.
- Airborne noise insulation in vertical surfaces.
- Airborne noise insulation in ceilings.
- Reduction of impact noise level in all types of frameworks applied underneath.

Its main applications include new construction and restoration works, industries, cinemas, theatres, sports complexes, night clubs, bars, restaurants, hotels, shopping centres...

Technical data

Test	Value
Tensile strength (UNE 104-281/6.6)	> 30 N/cm ² (Tecsound membrane)
Thermal conductivity coefficient	0.037 W/m·°C (felt)

Instructions for use

Support: Admits all habitual types of construction supports. The support must be even, clean, dry and preferably plastered. If the plaster coat is old, its condition should be checked to prevent problems with adherence of the TECSOUND 2FT to it.

Fitting: Apply LS Adhesive to the support and the complex. Leave to dry for 15-20 minutes. Line the Tecsound 2FT up over the support and fit in place.

Overlaps: The complex has a 5 cm overlap on two consecutive sides. The overlaps should be sealed with hot air or using the adhesive. The precaution of sealing the joins correctly should always be taken, as small openings can considerably reduce the acoustic insulation effect.

Presentation and storage

Type	kg/m ²	Thickness (mm)	Presentation	Pieces / pallet
Tecsound 2FT 45	4.7	22	Rolls 6 x 1,05 m	6 rolls (37.8 m ²)
Tecsound 2FT 80	8.2	24	Rolls 4 x 1,05 m	6 rolls (25.2 m ²)

The product should be stored in a dry place, protected against the elements, and not exposed to temperatures over 35 °C. The maximum recommended storage time is one year.

Auxiliary products

Type	Application	Approx. amount used	Presentation
Adhesivo LS	Adhesive for gluing Tecsound 2FT to the surfaces	600 – 750 gr/m ²	25 kg cans

TECSOUND® FT 55 AL is a soundproofing complex comprising a porous felt and the **TECSOUND®** synthetic membrane, coated on the outside with a film of reinforced aluminium.

Properties

- Increases acoustic insulation of the pipe it is applied to, its effect based on an absorbent element and a highly elastic, high-density insulating membrane.
- Easy handling and application.
- High flexibility.
- Excellent ageing-resistance.
- Rot-proof.
- Hot and cold-resistant.

Technical data

Test	Value
Density (TECSOUND® membrane)	1.9 g/cm ³
Pliability (UEAtc)	Does not break when bent at -10 °C
Tensile strength (UNE 104-281/6.6)	> 30 N/cm ² (TECSOUND® membrane)
Elongation (UNE 104-281/6.6)	300%
Thermal conductivity coefficient	0.037 W/m °C (felt)

Instructions for use

Support: The support surface must be free from materials that could damage the product during and subsequent to application, such as remains of mortar, etc...

Fitting: Measure the circumference of the pipe to be insulated, adding 5 cm for the overlap. Cut the required amount of TECSOUND® FT 55 AL crossways, using scissors.

Wrap the pipe so that the textile felt is in contact with the surface as much as possible, starting from the bottom of the pipe. Fasten it with a plastic flange every 20 cm. To seal the overlaps, use aluminium adhesive tape. It is important the joints are perfectly sealed to prevent reduction of the insulation.

Presentation and storage

Type	kg/m ²	Thickness (mm)	Presentation	Pieces / pallet
TECSOUND® FT 55 AL	5.5	12.6	Rolls de 5 x 1.05 m	10 rolls (52.50 m ²)

*The product should be stored in a dry place, protected against the elements, and not exposed to temperatures over 35 °C.
The maximum recommended storage time is one year.*



TEXSA, S.A.

C/ Ferro,7- Polígono Can Pelegrí
08755 Castellbisbal (Barcelona) Spain
Tel. (+34) 93 635 14 00 - Fax (+34) 93 635 14 80
E-mail: texsa@texsa.com

International Division

Tel. (+34) 93 635 14 52 - Fax (+34) 93 635 14 88
E-mail: texsa.international@texsa.com

<http://www.texsa.com>

ISO 9001



ER-280/1/94

